

DN6.65x - 48 channel 16 bit generatorNETBOX up to 125 MS/s

- 24, 32, 40 or 48 channels with 40 MS/s up to 125 MS/s
- Simultaneous arbitrary generation on all channels
- Output level $\pm 3.0\text{ V}$ into $50\ \Omega$ ($\pm 6\text{ V}$ into high-impedance loads)
- Fixed trigger to output delay
- Large 64 MSample per channel internal memory
- FIFO mode continuous streaming output
- Modes: Single-Shot, Loop, FIFO, Sequence Replay Mode, Gated, ...



- Ethernet Remote Instrument
- LXI Core 2011 compatible
- GBit Ethernet Interface
- Sustained streaming mode up to 100 MB/s
- Direct Connection to PC/Laptop
- Connect anywhere in company LAN
- Embedded Webserver for Maintenance/Updates
- Embedded Server option for open Linux platform

Operating Systems	SBench 6 Professional Included	Drivers
<ul style="list-style-type: none"> • Windows 7 (SP1), 8, 10, Server 2008 R2 and newer • Linux Kernel 2.6, 3.x, 4.x, 5.x • Windows/Linux 32 and 64 bit 	<ul style="list-style-type: none"> • Acquisition, Generation and Display of analog and digital data • Calculation, FFT • Documentation and Import, Export 	<ul style="list-style-type: none"> • LabVIEW, MATLAB, LabWindows/CVI • C/C++, GNU C++, VB.NET, C#, J#, Delphi, Java, Python • IVI

Model	Analog output channels		Output Level		Internal	
	Channels	Speed	in $50\ \Omega$	in $1\text{ M}\Omega$	Star-Hub	Modules
DN6.653-24	24	40 MS/s	$\pm 3\text{ V}$	$\pm 6\text{ V}$	yes	3
DN6.653-32	32	40 MS/s	$\pm 3\text{ V}$	$\pm 6\text{ V}$	yes	4
DN6.653-40	40	40 MS/s	$\pm 3\text{ V}$	$\pm 6\text{ V}$	yes	5
DN6.653-48	48	40 MS/s	$\pm 3\text{ V}$	$\pm 6\text{ V}$	yes	6
DN6.656-24	12	125 MS/s	$\pm 3\text{ V}$	$\pm 6\text{ V}$	yes	3
	24	80 MS/s				
DN6.656-32	16	125 MS/s	$\pm 3\text{ V}$	$\pm 6\text{ V}$	yes	4
	32	80 MS/s				
DN6.656-40	20	125 MS/s	$\pm 3\text{ V}$	$\pm 6\text{ V}$	yes	5
	40	80 MS/s				
DN6.656-48	24	125 MS/s	$\pm 3\text{ V}$	$\pm 6\text{ V}$	yes	6
	48	80 MS/s				

General Information

The general purpose Ethernet-AWG series generatorNETBOX DN6.65x allows generation of arbitrary signals on up to 48 channels in parallel. These Ethernet Remote instruments offer outstanding D/A features both in resolution and signal quality. The combination of high sampling rate and resolution makes these AWGs the top-of-the-range for applications that require high quality signal generation. The generatorNETBOX can be installed anywhere in the company LAN and can be remotely controlled from a host PC.

Software Support

Windows Support

The digitizerNETBOX/generatorNETBOX/hybridNETBOX can be accessed from Windows 7, Windows 8, Windows 10 (each 32 bit and 64 bit). Programming examples for Visual C++, C++ Builder, LabWindows/CVI, Delphi, Visual Basic, VB.NET, C#, J#, Python, Java and IVI are included.

Linux Support



The digitizerNETBOX/generatorNETBOX/hybridNETBOX can be accessed from any Linux system. The Linux support includes SMP systems, 32 bit and 64 bit systems, versatile programming examples for Gnu C++, Python as well as drivers for MATLAB for Linux.

SBench 6, the powerful data acquisition and analysis software from Spectrum is also included as a Linux version.

Discovery Protocol

Physical Location	
Bus No	0
Device No	0
Function No	0
Slot No	0
IP	192.168.169.14
VISA	TCPIP[0]:192.168.169.14:inst0:INSTR

The Discovery function helps you to find and identify any Spectrum LXI instruments, like the digitizerNETBOX and generatorNETBOX, available to your computer on the network.

The Discovery function will also locate any Spectrum card products that are managed by an installed Spectrum Remote Server somewhere on the network.

After running the discovery function the card information is cached and can be directly accessed by SBench 6. Furthermore the qualified VISA address is returned and can be used by any software to access the remote instrument.

SBench 6 Professional

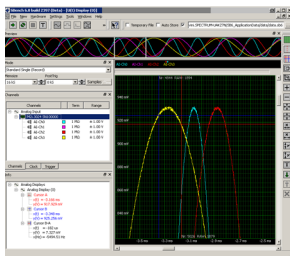

The digitizerNETBOX, generatorNETBOX and hybridNETBOX can be used with Spectrum's powerful software SBench 6 – a Professional license for the software is already installed in the box. SBench 6 supports all of the standard features of the instrument. It has a variety of display windows as well as analysis, export and documentation functions.

- Available for Windows 7, Windows 8, Windows 10 and Linux
- Easy to use interface with drag and drop, docking windows and context menus
- Display of analog and digital data, X-Y display, frequency domain and spread signals
- Designed to handle several GBytes of data
- Fast data preview functions

IVI Driver

The IVI standards define an open driver architecture, a set of instrument classes, and shared software components. Together these provide critical elements needed for instrument interchangeability. IVI's defined Application Programming Interfaces (APIs) standardize common measurement functions reducing the time needed to learn a new IVI instrument.

The Spectrum products to be accessed with the IVI driver can be locally installed data acquisition cards, remotely installed data acquisition cards or remote LXI instruments like digitizerNETBOX/generatorNETBOX. To maximize the compatibility with existing IVI based software installations, the Spectrum IVI

driver supports IVI Scope, IVI Digitizer and IVI FGen class with IVI-C and IVI-COM interfaces.

Third-party Software Products

Most popular third-party software products, such as LabVIEW, MATLAB or LabWindows/CVI are supported. All drivers come with examples and detailed documentation.

Embedded Webserver

Welcome	
Instrument Model	DNZ.465-08
Manufacturer	Spectrum GmbH
Serial Number	1234
Description	digitizerNETBOX
LXI Features	LXI Core 2011
LXI Version	LXI Device Specification 2011 rev. 1.4
Host Name	192.168.169.23
mDNS Host Name	digitizerNETBOX.local
MAC Address	0C:C4:7A:B3:C2:A2
TCP/IP Address	192.168.169.23
Firmware Revision	62
Software Revision	5.17.1717
Instrument Address String [VISA]	TCPIP::192.168.169.23::INSTR
LAN ID Indicator	<input type="checkbox"/> Enable

The integrated webserver follows the LXI standard and gathers information on the product, set up of the Ethernet configuration and current status. It also allows the setting of a configuration password, access to documentation and updating of the complete instrument firmware, including the embedded remote server and the webserver.

Hardware features and options

LXI Instrument



The digitizerNETBOX and generatorNETBOX are fully LXI instrument compatible to LXI Core 2011 following the LXI Device Specification

2011 rev. 1.4. The digitizerNETBOX/generatorNETBOX has been tested and approved by the LXI Consortium.

Located on the front panel is the main on/off switch, LEDs showing the LXI and Acquisition status and the LAN reset switch.

Front Panel



Standard BNC connectors are used for all analog input or output signals and all auxiliary signals like clock and trigger. No special adapter cables are needed and the connection is secure even when used in a moving environment.

Custom front panels are available on request even for small series, be it SMA, LEMO connectors or custom specific connectors.

Ethernet Connectivity



The GBit Ethernet connection can be used with standard COTS Ethernet cabling. The integration into a standard LAN allows to connect the digitizerNETBOX/generatorNETBOX either directly to a desktop PC or Laptop or it is possible to place the instrument somewhere in the

company LAN and access it from any desktop over the LAN.

Boot on Power Option

The digitizerNETBOX/generatorNETBOX can be factory configured to automatically start and boot upon availability of the input power rail. That way the instrument will automatically become available again upon loss of input power.

Option Embedded Server

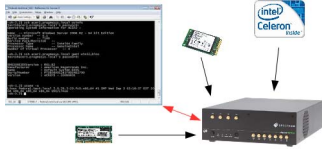

The option turns the digitizerNETBOX/generatorNETBOX in a powerful PC that allows to run own programs on a small and remote data acquisition system. The digitizerNETBOX/generatorNETBOX is enhanced by more memory, a powerful CPU, a freely accessible internal SSD and a remote software development access method.

The digitizerNETBOX/generatorNETBOX can either run connected to LAN or it can run totally independent, storing data to the internal SSD. The original digitizerNETBOX/generatorNETBOX remote instrument functionality is still 100 % available. Running the embedded server option it is possible to pre-calculate results based on the acquired data, store acquisitions locally and to transfer just the required data or results parts in a client-server based software structure. A different example for the digitizerNETBOX/generatorNETBOX embedded server is surveillance/logger application which can run totally independent for days and send notification emails only over LAN or offloads stored data as soon as it's connected again.

Access to the embedded server is done through a standard text based Linux shell based on the ssh secure shell.

Singleshot output

When singleshot output is activated the data of the on-board memory is played exactly one time. The trigger source can be either one of the external trigger inputs or the software trigger. After the first trigger additional trigger events will be ignored.

Repeated output

When the repeated output mode is used the data of the on-board memory is played continuously for a programmed number of times or until a stop command is executed. The trigger source can be either one of the external trigger inputs or the software trigger. After the first trigger additional trigger events will be ignored.

Single Restart replay

When this mode is activated the data of the on-board memory will be replayed once after each trigger event. The trigger source can be either the external TTL trigger or software trigger.

FIFO mode

The FIFO mode is designed for continuous data transfer between PC memory or hard disk and the generation board. The control of the data stream is done automatically by the driver on an interrupt request basis. The complete installed on-board memory is used for buffering data, making the continuous streaming extremely reliable.

Multiple Replay

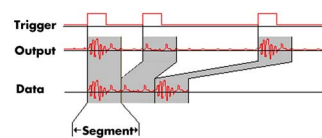

The Multiple Replay mode allows the fast output generation on several trigger events without restarting the hardware. With this option very fast repetition rates can be achieved.

The on-board memory is divided into several segments of the same size. Each segment can contain different data which will then be played with the occurrence of each trigger event.

Gated Replay

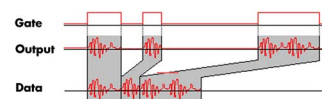

The Gated Sampling mode allows data replay controlled by an external gate signal. Data is only replayed if the

gate signal has attained a programmed level.

Sequence Mode

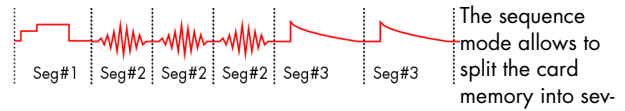

The sequence mode allows to split the card memory into several

data segments of different length. These data segments are chained up in a user chosen order using an additional sequence memory. In this sequence memory the number of loops for each segment can be programmed and trigger conditions can be defined to proceed from segment to segment. Using the sequence mode it is also possible to switch between replay waveforms by a simple software command or to redefine waveform data for segments simultaneously while other segments are being replayed. All trigger-related and software-command-related functions are only working on single cards, not on star-hub-synchronized cards.

External trigger input

All boards can be triggered using up to two external analog or digital signals. One external trigger input has two analog comparators that can define an edge or window trigger, a hysteresis trigger or a rearm trigger. The other input has one comparator that can be used for standard edge and level triggers.

External clock input and output

Using a dedicated connector a sampling clock can be fed in from an external system. Additionally it's also possible to output the internally used sampling clock on a separate connector to synchronize external equipment to this clock.

Reference clock

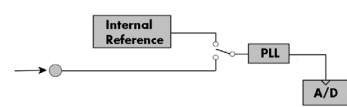

The option to use a precise external reference clock (normally 10 MHz) is necessary to synchronize the instrument for high-quality measurements with external equipment (like a signal source). It's also possible to enhance the quality of the sampling clock in this way. The driver automatically generates the requested sampling clock from the fed in reference clock.

DN2 / DN6 Technical Data

Analog Outputs

Resolution		16 bit
D/A Interpolation		no interpolation
Output amplitude	software programmable	653x and 656x: ± 1 mV up to ± 3 V in 1 mV steps into 50 Ω termination (resulting in ± 2 mV up to ± 6 V in 2mV steps into high impedance loads) 654x and 657x: ± 1 mV up to ± 6 V in 1 mV steps into 50 Ω termination (resulting in ± 2 mV up to ± 12 V in 2mV steps into high impedance loads) Note: Gain values below ± 300 mV into 50 Ω are reduced by digital scaling of the samples
Output Amplifier Path Selection	automatically by driver	Low Power path: Selected Gain of ± 1 mV to ± 960 mV (into 50 Ω) High Power path: 653x and 656x: Selected Gain of ± 940 mV to ± 3 V (into 50 Ω) 654x and 657x: Selected Gain of ± 940 mV to ± 6 V (into 50 Ω)
Output Amplifier Setting Hysteresis	automatically by driver	940 mV to 960 mV (if output is using low power path it will switch to high power path at 960 mV. If output is using high power path it will switch to low power path at 940 mV)
Output amplifier path switching time		1.2 ms (output disabled while switching)
Output offset	software programmable	Low Power path: ± 960 mV in 1 mV steps into 50 Ω (± 1920 mV in 2 mV steps into 1 M Ω) High Power path: 653x and 656x: ± 3 V in 1 mV steps into 50 Ω (± 6 V in 2 mV steps into 1 M Ω) 654x and 657x: ± 6 V in 1 mV steps into 50 Ω (± 12 V in 2 mV steps into 1 M Ω)
Filters	software programmable	One of 4 different filters (refer to „Bandwidth and Filters“ section)
DAC Differential non linearity (DNL)	DAC only	± 2.0 LSB typical
DAC Integral non linearity (INL)	DAC only	± 4.0 LSB typical
Output resistance		50 Ω
Minimum output load		653x and 656x: 0 Ω (short circuit safe by design) 654x and 657x: 50 Ω (short circuit safe by hardware supervisor, outputs will turn off)
Max output swing in 50 Ω		653x and 656x: ± 3.0 V (offset + amplitude) 654x and 657x: ± 6.0 V (offset + amplitude)
Max output swing in 1 M Ω		653x and 656x: ± 6.0 V (offset + amplitude) 654x and 657x: ± 12.0 V (offset + amplitude)
Max output current		653x and 656x: ± 30 mA 654x and 657x: ± 60 mA
Slewrate (using Filter 0)		Low power path (0 to 900 mV): 250 mV/ns 653x and 656x: High power path (0 to 3000 mV): 850 mV/ns 654x and 657x: High power path (0 to 6000 mV): TBD
Rise/Fall time 10% to 90% square wave		653x and 656x: ± 3 V square wave: 5.3 ns 654x and 657x: ± 3 V square wave: TBD
Crosstalk @ 1 MHz signal ± 3 V	1 to 4 ch standard AWG	95 dB (M2p.6530, M2p.6531, M2p.6536, M2p.6560, M2p.6561, M2p.6566)
Crosstalk @ 1 MHz signal ± 3 V	8 channel AWG	84 dB (M2p.6533, M2p.6568)
Crosstalk @ 1 MHz signal ± 6 V	1 to 4 ch high-voltage AWG	99 dB (M2p.6540, M2p.6541, M2p.6546, M2p.6540, M2p.6541, M2p.6546)
Output accuracy		± 1 mV ± 0.5 % of programmed output amplitude ± 0.1 % of programmed output offset

Trigger

Available trigger modes	software programmable	External, Software, Pulse, Or/And, Delay
Trigger edge	software programmable	Rising edge, falling edge or both edges
Trigger pulse width	software programmable	0 to [4G - 1] samples in steps of 1 sample
Trigger delay	software programmable	0 to [4G - 1] samples in steps of 1 samples
Trigger holdoff (for Multi, Gate)	software programmable	0 to [4G - 1] samples in steps of 1 samples
Multi, Gate: re-arming time		< 24 samples (+ programmed holdoff)
Trigger to Output Delay		63 sample clocks + 7 ns
Memory depth	software programmable	16 up to [installed memory / number of active channels] samples in steps of 8
Multiple Replay segment size	software programmable	8 up to [installed memory / number of active channels] samples in steps of 8
External trigger accuracy		1 sample
External trigger		Ext
External trigger type		Single level comparator
External trigger impedance	software programmable	50 Ω / 5 k Ω
External trigger input level		± 5 V (5 k Ω), ± 2.5 V (50 Ω), ± 20 V (5 k Ω), 5 Vrms (50 Ω)
External trigger over voltage protection		200 mVpp
External trigger sensitivity (minimum required signal swing)		
External trigger level	software programmable	± 5 V in steps of 1 mV
External trigger bandwidth	50 Ω 5 k Ω	DC to 400 MHz DC to 300 MHz
Minimum external trigger pulse width		≥ 2 samples
		X1, X2, X3
		3.3V LVTTTL logic inputs
		For electrical specifications refer to „Multi Purpose I/O lines“ section.
		n.a.
		DC to 125 MHz
		≥ 2 samples

Multi Purpose I/O lines

Number of multi purpose output lines		one, named X0
Number of multi purpose input/output lines		three, named X1, X2, X3
Multi Purpose line		X0
Input: available signal types	software programmable	n.a.
Input: signal levels		n.a.
Input: impedance		n.a.
Input: maximum voltage level		n.a.
Input: maximum bandwidth		n.a.
Output: available signal types	software programmable	Run-, Arm-, Trigger-Output, Marker-Output, Synchronous Digital-Out, Asynchronous Digital-Out, ADC Clock Output,
		X1, X2, X3
		Asynchronous Digital-In, Logic trigger
		3.3 V LVTTTL
		10 k Ω to 3.3 V
		-0.5 V to +4.0 V
		125 MHz
		Run-, Arm-, Trigger-Output, Marker-Output, Synchronous Digital-Out, Asynchronous Digital-Out,
Output: impedance		50 Ω
Output: drive strength		Capable of driving 50 Ω loads, maximum drive strength ± 48 mA
Output: type / signal levels		3.3V LVTTTL, TTL compatible for high impedance loads
Output: update rate (synchronous modes)		sampling clock

Sequence Replay Mode

Number of sequence steps	software programmable	1 up to 4096 (sequence steps can be overloaded at runtime)
Number of memory segments	software programmable	2 up to 64k (segment data can be overloaded at runtime)
Minimum segment size	software programmable	32 samples in steps of 8 samples.
Maximum segment size	software programmable	512 MS / active channels / number of sequence segments (round up to the next power of two)
Loop Count	software programmable	1 to (1M - 1) loops
Sequence Step Commands	software programmable	Loop for #Loops, Next, Loop until Trigger, End Sequence
Special Commands	software programmable	Data Overload at runtime, sequence steps overload at runtime, readout current replayed sequence step
Limitations for synchronized products		Software commands changing the sequence as well as „Loop until trigger“ are not synchronized between cards. This also applies to multiple AWG modules in a generatorNETBOX.

Clock

Clock Modes	software programmable	internal PLL, external clock, external reference clock, sync
Internal clock range (PLL mode)	software programmable	see „Clock Limitations“ table below
Internal clock accuracy	after warm-up	$\leq \pm 1.0$ ppm (at time of calibration in production)
Internal clock aging		$\leq \pm 0.5$ ppm / year
PLL clock setup granularity (int. or ext. reference)		1 Hz
External reference clock range	software programmable	128 kHz up to 125 MHz
Direct external clock to internal clock delay		4.3 ns
Direct external clock range		see „Clock Limitations and Bandwidth“ table below
External clock type		Single level comparator
External clock input level		± 5 V (5 k Ω), ± 2.5 V (50 Ω),
External clock input impedance	software programmable	50 Ω / 5 k Ω
External clock over voltage protection		± 20 V (5 k Ω), 5 Vrms (50 Ω)
External clock sensitivity (minimum required signal swing)		200 mVpp
External clock level	software programmable	± 5 V in steps of 1 mV
External clock edge		rising edge used
External reference clock input duty cycle		45% - 55%
Clock output electrical specification		Available via Multi Purpose output X0. Refer to „Multi Purpose I/O lines“ section.
Synchronization clock multiplier „N“ for different clocks on synchronized cards	software programmable	N being a multiplier (1, 2, 3, 4, 5, ... Max) of the card with the currently slowest sampling clock. The card maximum (see „Clock Limitations and Bandwidth“ table below) must not be exceeded.
Channel to channel skew on one card		< 200 ps (typical)
Skew between star-hub synchronized cards		TBD

Connectors

Analog Inputs		9 mm BNC female (one for each single-ended input)	Cable-Type: Cab-9m-xx-xx
Trigger Input		9 mm BNC female	Cable-Type: Cab-9m-xx-xx
Clock/Reference Clock Input		9 mm BNC female	Cable-Type: Cab-9m-xx-xx
Clock Output, Multi-Purpose X0		9 mm BNC female	Cable-Type: Cab-9m-xx-xx
Multi-Purpose I/O X1, X2, X3	Programmable Direction	9 mm BNC female	Cable-Type: Cab-9m-xx-xx

Option digitizerNETBOX/generatorNETBOX embedded server (DN2.xxx-Emb, DN6.xxx-Emb)

CPU		Intel Quad Core 2 GHz	
System memory		4 GByte RAM	
System data storage		Internal 128 GByte SSD	
Development access		Remote Linux command shell (ssh), no graphical interface (GUI) available	
Accessible Hardware		Full access to Spectrum instruments, LAN, front panel LEDs, RAM, SSD	
Integrated operating system		OpenSuse 12.2 with kernel 4.4.7.	
Internal PCIe connection		DN2.20, DN2.46, DN2.47, DN2.49, DN2.59, DN2.60, DN2.65	PCIe x1, Gen1
		DN6.46, DN6.49, DN6.59, DN6.65	
		DN2.22, DN2.44, DN2.66	PCIe x1, Gen2
		DN6.22, DN6.44, DN6.66	

Ethernet specific details

LAN Connection		Standard RJ45
LAN Speed		Auto Sensing: GBit Ethernet, 100BASE-T, 10BASE-T
LAN IP address	programmable	DHCP (IPv4) with AutoIP fall-back (169.254.x.y), fixed IP (IPv4)
Sustained Streaming speed		DN2.20, DN2.46, DN2.47, DN2.49, DN2.60 up to 70 MByte/s DN6.46, DN6.49
		DN2.59, DN2.65, DN2.22, DN2.44, DN2.66 up to 100 MByte/s DN6.59, DN6.65, DN6.22, DN6.44, DN6.66
Used TCP/UDP Ports		Webserver: 80 mDNS Daemon: 5353 VISA Discovery Protocol: 111, 9757 UPNP Daemon: 1900 Spectrum Remote Server: 1026, 5025

Power connection details

Mains AC power supply	Input voltage: 100 to 240 VAC, 50 to 60 Hz
AC power supply connector	IEC 60320-1-C14 (PC standard coupler)
Power supply cord	power cord included for Schuko contact (CEE 7/7)

Serial connection details (DN2.xxx with hardware \geq V11)

Serial connection (RS232)	For diagnostic purposes only. Do not use, unless being instructed by a Spectrum support agent.
---------------------------	--

Certification, Compliance, Warranty

EMC Immunity	Compliant with CE Mark
EMC Emission	Compliant with CE Mark
Product warranty	5 years starting with the day of delivery
Software and firmware updates	Life-time, free of charge

Clock Limitations

	M2p.653x DNx.653-xx M2p.654x DNx.654-xx DNx.803-xx DNx.813-xx	M2p.656x DNx.656-xx M2p.657x DNx.657-xx DNx.806-xx DNx.816-xx
max internal clock (non-synchronized cards)	40 MS/s	125 MS/s
min internal clock (non-synchronized cards)	1 kS/s	1 kS/s
max internal clock (cards synchronized via star-hub)	40 MS/s	125 MS/s
min internal clock (cards synchronized via star-hub)	128 kS/s	128 kS/s
max direct external clock	40 MS/s	125 MS/s
min direct external clock	DC	DC
min direct external clock LOW time	4 ns	4 ns
min direct external clock HIGH time	4 ns	4 ns

Bandwidth and Filters

	Filter	- 3dB bandwidth	Filter characteristic
Analog bandwidth does not include Sinc response of DAC	Filter 0	70 MHz	third-order Butterworth
	Filter 1	20 MHz	fifth-order Butterworth
	Filter 2	5 MHz	fourth-order Bessel
	Filter 3	1 MHz	fourth-order Bessel

Dynamic Parameters

M2p.653x/DNx.653-xx/DNx.803-xx				
Test - Samplerate	40 MS/s		40 MS/s	
Output Frequency	800 kHz		4 MHz	
Output Level in 50 Ω	±900mV	±3000mV	±900mV	±3000mV
Used Filter	1 MHz		5 MHz	
NSD (typ)	-142 dBm/Hz	-132 dBm/Hz	-142 dBm/Hz	-132 dBm/Hz
SNR (typ)	90.7 dB	91.1 dB	83.7 dB	84.1 dB
THD (typ)	-74.0 dB	-74.0 dB	-70.5 dB	-70.5 dB
SINAD (typ)	73.9 dB	73.9 dB	69.8 dB	69.8 dB
SFDR (typ), excl harm.	97.0 dB	95.0 dB	88.0 dB	88.0 dB
ENOB (SINAD)	12.0	12.0	11.3	11.3
ENOB (SNR)	14.7	14.8	13.5	13.6

M2p.654x/DNx.654-xx/DNx.813-xx				
Test - Samplerate	40 MS/s		40 MS/s	
Output Frequency	800 kHz		4 MHz	
Output Level in 50 Ω	±900mV	±6000mV	±900mV	±6000mV
Used Filter	1 MHz		5 MHz	
NSD (typ)	-138 dBm/Hz	-129 dBm/Hz	-142 dBm/Hz	-126 dBm/Hz
SNR (typ)	86.7 dB	88.1 dB	83.7 dB	84.2 dB
THD (typ)	-74.0 dB	-74.0 dB	-74.0 dB	-74.0 dB
SINAD (typ)	73.8 dB	73.8 dB	73.6 dB	73.6 dB
SFDR (typ), excl harm.				
ENOB (SINAD)	12.0	12.0	11.9	11.9
ENOB (SNR)	14.1	14.3	13.6	13.7

M2p.656x/DNx.656-xx/DNx.806-xx						
Test - Samplerate	125 MS/s		125 MS/s		125 MS/s	
Output Frequency	800 kHz		4 MHz		16 MHz	
Used Filter	1 MHz		5 MHz		20 MHz	
Output Level in 50 Ω	±900mV	±3000mV	±900mV	±3000mV	±900mV	±3000mV
NSD (typ)	-142 dBm/Hz	-132 dBm/Hz	-142 dBm/Hz	-132 dBm/Hz	-142 dBm/Hz	-132 dBm/Hz
SNR (typ)	90.7 dB	91.1 dB	83.7 dB	84.1 dB	77.7 dB	78.1 dB
THD (typ)	-74.0 dB	-74.0 dB	-70.5 dB	-70.5 dB	-66.0 dB	-61.9 dB
SINAD (typ)	73.9 dB	73.9 dB	69.8 dB	69.8 dB	65.7 dB	60.9 dB
SFDR (typ), excl harm.	97.0 dB	95.0 dB	88.0 dB	88.0 dB	90.0 dB	89.0 dB
ENOB (SINAD)	12.0	12.0	11.3	11.3	10.6	9.8
ENOB (SNR)	14.7	14.8	13.5	13.6	12.5	12.6

M2p.657x/DNx.657-xx/DNx.816-xx						
Test - Samplerate	125 MS/s		125 MS/s		125 MS/s	
Output Frequency	800 kHz		4 MHz		16 MHz	
Used Filter	1 MHz		5 MHz		20 MHz	
Output Level in 50 Ω	±900mV	±6000mV	±900mV	±6000mV	±900mV	±6000mV
NSD (typ)	-138 dBm/Hz	-129 dBm/Hz	-142 dBm/Hz	-126 dBm/Hz	-142 dBm/Hz	-127 dBm/Hz
SNR (typ)	86.7 dB	88.1 dB	83.7 dB	84.2 dB	77.7 dB	79.1 dB
THD (typ)	-74.0 dB	-74.0 dB	-74.0 dB	-74.0 dB	-70.5 dB	-63.1 dB
SINAD (typ)	73.8 dB	73.8 dB	73.6 dB	73.6 dB	69.7 dB	63.0 dB
SFDR (typ), excl harm.						
ENOB (SINAD)	12.0	12.0	11.9	11.9	11.3	10.2
ENOB (SNR)	14.1	14.3	13.6	13.7	12.6	12.8

THD and SFDR are measured at the given output level and 50 Ohm termination with a high resolution M3i.4860/M4i.4450-x8 data acquisition card and are calculated from the spectrum. Noise Spectral Density is measured with built-in calculation from an HP E4401B Spectrum Analyzer. All available D/A channels are activated for the tests. SNR and SFDR figures may differ depending on the quality of the used PC. NSD = Noise Spectral Density, THD = Total Harmonic Distortion, SFDR = Spurious Free Dynamic Range.

DN6 specific Technical Data

Environmental and Physical Details DN6.xxx

Dimension of Chassis without connectors or bumpers	L x W x H	464 mm x 431 mm x 131 mm
Dimension of Chassis with 19" rack mount option	L x W x H	464 mm x TBD mm x 131 mm (3U height)
Weight (3 internal acquisition/generation modules)		12.1 kg, with rack mount kit: TBD kg
Weight (4 internal acquisition/generation modules)		12.5 kg, with rack mount kit: TBD kg
Weight (5 internal acquisition/generation modules)		12.9 kg, with rack mount kit: TBD kg
Weight (6 internal acquisition/generation modules)		13.4 kg, with rack mount kit: TBD kg
Warm up time		10 minutes
Operating temperature		0°C to 40°C
Storage temperature		-10°C to 70°C
Humidity		10% to 90%
Dimension of packing (single DN6)	L x W x H	580 mm x 580 mm x 280 mm
Volume weight of Packing (single DN6)		19.0 kgs

Power Consumption

	230 VAC	
24 channel versions, standard memory	TBD	TBD
32 channel versions, standard memory	TBD	TBD
40 channel versions, standard memory	TBD	TBD
48 channel versions, standard memory	TBD	TBD

MTBF

MTBF	TBD hours
------	-----------

Block diagram of generatorNETBOX DN6

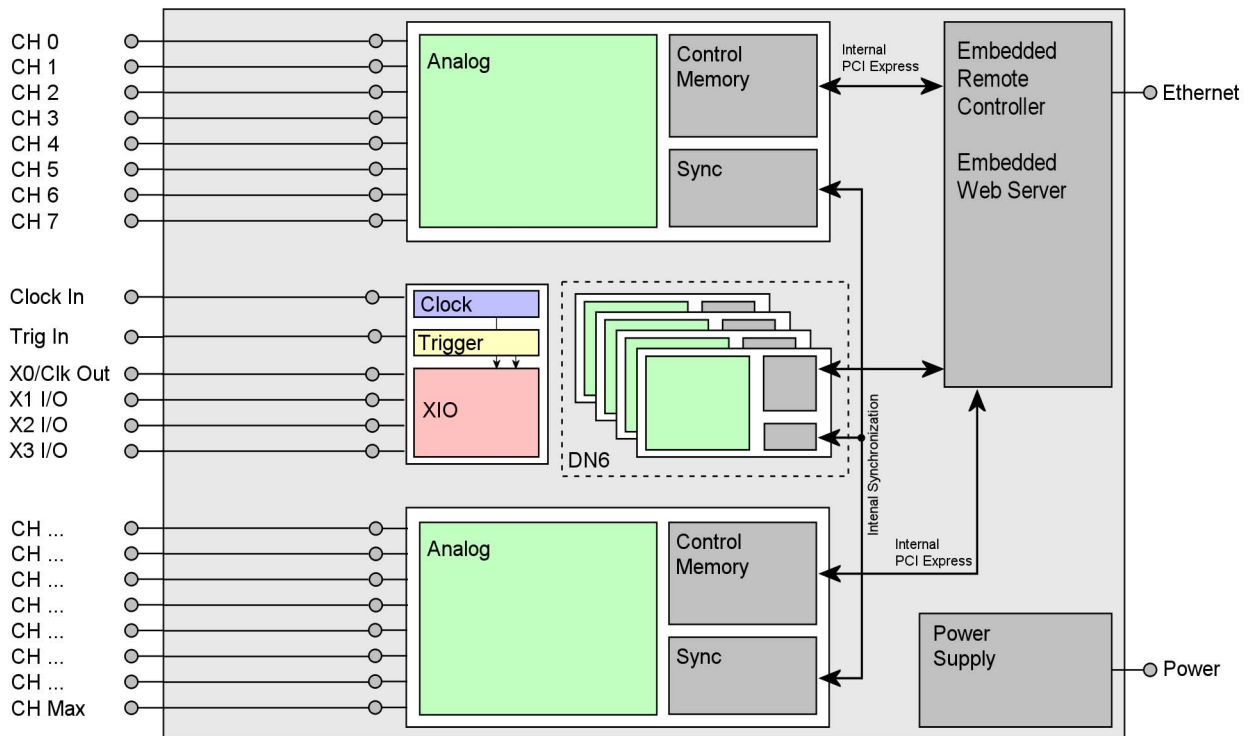

- The number of maximum channels and internal AWG modules and existence of a synchronization Star-Hub is model dependent.

Block diagram of generatorNETBOX module DN6.65x

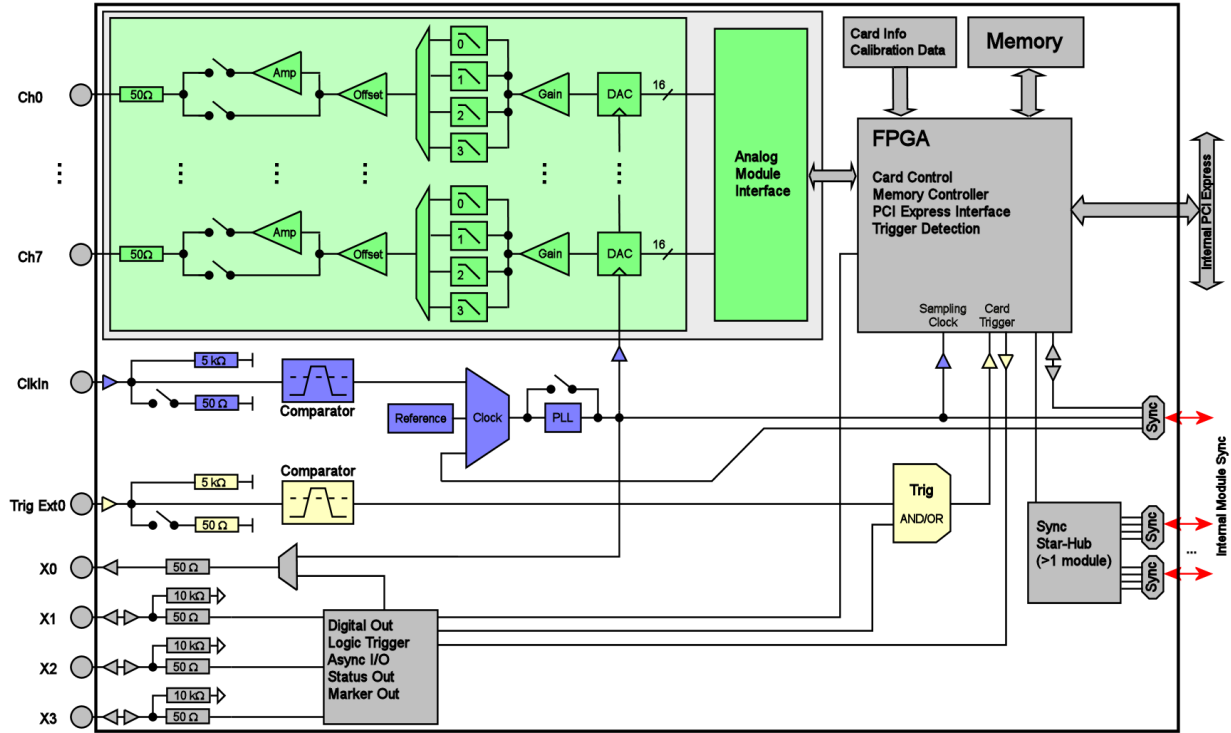

Order Information

The digitizerNETBOX is equipped with a large internal memory for data storage and supports standard acquisition (Scope), FIFO acquisition (streaming), Multiple Recording, Gated Sampling, ABA mode and Timestamps. Operating system drivers for Windows/Linux 32 bit and 64 bit, drivers and examples for C/C++, IVI (Scope and Digitizer class), LabVIEW (Windows), MATLAB (Windows and Linux), .NET, Delphi, Java, Python and a Professional license of the oscilloscope software SBench 6 are included.

The system is delivered with a connection cable meeting your countries power connection. Additional power connections with other standards are available as option.

digitizerNETBOX DN6 - Ethernet/LXI Interface

Order no.	Resolution	Output Channels	Memory	Output@50Ω	Output@1MΩ
DN6.653-24	16 Bit	24 channels 40 MS/s	3 x 512 MSamples	±3V	±6V
DN6.653-32	16 Bit	32 channels 40 MS/s	4 x 512 MSamples	±3V	±6V
DN6.653-40	16 Bit	40 channels 40 MS/s	5 x 512 MSamples	±3V	±6V
DN6.653-48	16 Bit	48 channels 40 MS/s	6 x 512 MSamples	±3V	±6V
DN6.656-24	16 Bit	12 channels 125 MS/s 24 channels 80 MS/s	3 x 512 MSamples	±3V	±6V
DN6.656-32	16 Bit	16 channels 125 MS/s 32 channels 80 MS/s	4 x 512 MSamples	±3V	±6V
DN6.656-40	16 Bit	20 channels 125 MS/s 40 channels 80 MS/s	5 x 512 MSamples	±3V	±6V
DN6.656-48	16 Bit	24 channels 125 MS/s 48 channels 80 MS/s	6 x 512 MSamples	±3V	±6V

Options

Order no.	Option
DN6.xxx-Rack	19" rack mounting set for self mounting
DN6.xxx-Emb	Extension to Embedded Server: CPU, more memory, SSD. Access via remote Linux secure shell (ssh)
DN6.xxx-BTPWR	Boot on Power On: the digitizerNETBOX/generatorNETBOX automatically boots if power is switched on.

BNC Cables

The standard adapter cables are based on RG174 cables and have a nominal attenuation of 0.3 dB/m at 100 MHz.

for Connections	Connection	Length	to SMA male	to SMA female	to BNC male	to SMB female
All	BNC male	80 cm	Cab-3mA-9m-80	Cab-3fA-9m-80	Cab-9m-9m-80	Cab-3f-9m-80
All	BNC male	200 cm	Cab-3mA-9m-200	Cab-3fA-9m-200	Cab-9m-9m-200	Cab-3f-9m-200

Technical changes and printing errors possible

SBench, digitizerNETBOX and generatorNETBOX are registered trademarks of Spectrum Instrumentation GmbH. Microsoft, Visual C++, Windows, Windows 98, Windows NT, Window 2000, Windows XP, Windows Vista, Windows 7, Windows 8 and Windows 10 are trademarks/registered trademarks of Microsoft Corporation. LabVIEW, DASyLab, Diadem and LabWindows/CVI are trademarks/registered trademarks of National Instruments Corporation. MATLAB is a trademark/registered trademark of The Mathworks, Inc. Delphi and C++Builder are trademarks/registered trademarks of Embarcadero Technologies, Inc. Keysight VEE, VEE Pro and VEE Onelab are trademarks/registered trademarks of Keysight Technologies, Inc. FlexPro is a registered trademark of Weisang GmbH & Co. KG. PCIe, PCI Express and PCI-X and PCI-SIG are trademarks of PCI-SIG. LXI is a registered trademark of the LXI Consortium. PICMG and CompactPCI are trademarks of the PCI Industrial Computation Manufacturers Group. Oracle and Java are registered trademarks of Oracle and/or its affiliates. Intel and Intel Core i3, Core i5, Core i7, Core i9 and Xeon are trademarks and/or registered trademarks of Intel Corporation. AMD, Opteron, Sempron, Phenom, FX, Ryzen and EPYC are trademarks and/or registered trademarks of Advanced Micro Devices. NVIDIA, CUDA, GeForce, Quadro and Tesla are trademarks/registered trademarks of NVIDIA Corporation.