

PLEORA TECHNOLOGIES INC.



## iPORT CL-U3 External Frame Grabber User Guide



## Copyright © 2021 Pleora Technologies Inc.

These products are not intended for use in life support appliances, devices, or systems where malfunction of these products can reasonably be expected to result in personal injury. Pleora Technologies Inc. (Pleora) customers using or selling these products for use in such applications do so at their own risk and agree to indemnify Pleora for any damages resulting from such improper use or sale.

## Trademarks

CoreGEV, PureGEV, eBUS, iPORT, vDisplay, AutoGEV, AutoGen, and all product logos are trademarks of Pleora Technologies. Third party copyrights and trademarks are the property of their respective owners.

## Notice of Rights

All information provided in this manual is believed to be accurate and reliable. No responsibility is assumed by Pleora for its use. Pleora reserves the right to make changes to this information without notice. Redistribution of this manual in whole or in part, by any means, is prohibited without obtaining prior permission from Pleora.

## Document Number

EX001-023-0012 Version 2.0, 2/26/21



# Important Power Information



To avoid damage to the CL-U3 (and in some cases the connected equipment), it is important that you follow the correct power sequence:

- If you are using GPIO inputs, set the **Differential Type** switch (industrial models only) and **I/O Level** switch (all models) **BEFORE** you connect equipment and **BEFORE** you apply power to the CL-U3.
- Always power up the CL-U3 **BEFORE** the camera:
  - Power up the CL-U3 and wait until it is fully powered (the Power/FPGA status LED is green).
  - Connect the camera to the CL-U3.
  - Apply power to the camera.
- Always power down the camera **BEFORE** you power down the CL-U3.

## Complete Power Information and Instructions

Table 1: Complete Power Information and Instructions

Models	Power information and instructions
<b>CL-U3B</b> <i>Order Codes:</i> 903-0007, 903-0011 <i>Device Model Name:</i> iPORT-CL-U3-PT03-CLOUP01-128x	<b>Important Overview: “Powering the CL-U3” on page 26</b> <ul style="list-style-type: none"><li>• “Differential Type and I/O Level Switches” on page 22</li><li>• “Powering the CL-U3B and CL-U3M Using USB 3.0” on page 26</li></ul>
<b>CL-U3B-IND</b> <i>Order Codes:</i> 903-0009, 903-0019, 903-0013 <i>Device Model Name:</i> iPORT-CL-U3-PT03-CLOUP02-128x	<b>Important Overview: “Powering the CL-U3” on page 26</b> <ul style="list-style-type: none"><li>• “Differential Type and I/O Level Switches” on page 22</li><li>• “Powering the CL-U3B-IND and CL-U3M-IND Using an External Power Supply” on page 27</li></ul>
<b>CL-U3M</b> <i>Order Codes:</i> 903-0008, 903-0012 <i>Device Model Name:</i> iPORT-CL-U3-PT03-CLOUP03-128x	<b>Important Overview: “Powering the CL-U3” on page 26</b> <ul style="list-style-type: none"><li>• “Differential Type and I/O Level Switches” on page 22</li><li>• “Powering the CL-U3B and CL-U3M Using USB 3.0” on page 26</li></ul>
<b>CL-U3M-IND</b> <i>Order Codes:</i> 903-0010, 903-0020, 903-0014 <i>Device Model Name:</i> iPORT-CL-U3-PT03-CLOUP04-128x	<b>Important Overview: “Powering the CL-U3” on page 26</b> <ul style="list-style-type: none"><li>• “Differential Type and I/O Level Switches” on page 22</li><li>• “Powering the CL-U3B-IND and CL-U3M-IND Using an External Power Supply” on page 27</li></ul>



# Ensuring Proper Image Streaming From a Camera Link Camera

**Important:** Before you attempt to stream images, you must know the image settings of your Camera Link camera, and then configure the CL-U3 with matching image settings.

## Steps to Ensure Proper Image Streaming

1. Ensure that you have installed Pleora's eBUS SDK and supporting drivers on your computer. For more information, see ["Installing the eBUS Universal Pro Driver"](#) on page 48.
2. Physically connect the camera, CL-U3, and computer. Power up the system. For more information, see ["CL-U3 Connections"](#) on page 13.
3. Test the connection between the CL-U3 and the computer using the test pattern. For more information, see ["Confirming Image Streaming"](#) on page 52.
4. You must now set up Camera Link serial communications to allow eBUS Player to communicate with your camera. For more information, see ["Accessing your Camera Settings through Camera Link Serial Communications"](#) on page 53.
5. After you have configured the image settings on the camera, you must then configure matching image settings on the CL-U3. For more information about configuring CL-U3 settings, see ["Configuring CL-U3 Image Settings Using eBUS Player"](#) on page 55.



The changes that you make to your CL-U3 are temporary and WILL NOT PERSIST ACROSS POWER CYCLES. Save your settings using the steps outlined in the section, ["Saving eBUS Player and CL-U3 Settings"](#) on page 69 to avoid losing changes when the CL-U3 is power-cycled.



# Table of Contents

Important Power Information .....	i
Ensuring Proper Image Streaming From a Camera Link Camera .....	iii
About this Guide .....	1
What this Guide Provides .....	2
Documented Product Versions .....	2
Related Documents .....	3
Further Reading .....	3
About the iPORT CL-U3 External Frame Grabber .....	5
Models .....	6
Feature Set .....	10
Key GenICam Features .....	11
Available Pixel Formats .....	12
CL-U3 Connections .....	13
Connector and Switch Locations .....	14
Micro-B USB 3.0 Connector .....	16
Locking Connectors .....	16
Camera Link Connectors .....	17
Powering a Camera using Power Over Camera Link (PoCL) .....	17
Voltage Drop Monitoring .....	18
Mapping to the Serial Communication Interface .....	18
Mapping of Camera Link Connector and 12-Pin GPIO Connector Inputs .....	18
12-Pin GPIO Connector .....	19
12-Pin GPIO Connector Pinouts — Standard Models .....	20
12-Pin GPIO Connector Pinouts — Industrial Models .....	21
Differential Type and I/O Level Switches .....	22
Differential and Single-Ended Input/Output Specifications .....	24
Powering the CL-U3 .....	26
Powering the CL-U3B and CL-U3M Using USB 3.0 .....	26
Powering the CL-U3B-IND and CL-U3M-IND Using an External Power Supply .....	27
Power Consumption .....	28
Status LEDs .....	30
Ambient and Junction Temperatures .....	33
Handling GPIO, Camera Control, and PLC Input and Output Programming Signals .....	35
PLC Input and Output Programming Signals .....	36
Using Quadrature Encoders .....	38
Differential Connection .....	39
Single-Ended Connection .....	39
Processing Quadrature Encoder Signals .....	40

<b>Bulk Interfaces</b> .....	<b>43</b>
GenICam Interface for Serial Communication Configuration .....	44
UART Timing .....	44
<b>Installing the eBUS SDK</b> .....	<b>47</b>
Installing the eBUS SDK .....	48
Installing the eBUS Universal Pro Driver .....	48
<b>Connecting to the CL-U3 and Configuring General Settings Using eBUS Player</b> .....	<b>51</b>
Confirming Image Streaming .....	52
Accessing your Camera Settings through Camera Link Serial Communications .....	53
Configuring CL-U3 Image Settings Using eBUS Player .....	55
Supported Device Tap Geometries for the CL-U3 .....	56
Enabling SafePower and PoCL .....	59
Viewing and Testing Streaming Images .....	61
Configuring the Buffers .....	62
Calculating the Required Bandwidth .....	63
Specifying How Images are Acquired .....	64
Continuous Mode .....	65
Multiframe Mode .....	65
SingleFrame Mode .....	65
Recording and Retrieving Images in the Onboard Memory .....	66
ContinuousRecording Mode .....	66
ContinuousReadout Mode .....	67
MultiFrameRecording Mode .....	67
SingleFrameRecording Mode .....	67
SingleFrameReadout Mode .....	67
Understanding When Images are Removed from the Onboard Memory .....	68
Calculating How Many Images Can be Stored in Onboard Memory .....	68
Implementing the eBUS SDK .....	68
<b>Saving eBUS Player and CL-U3 Settings</b> .....	<b>69</b>
Choosing the Best Method for Saving eBUS Player and CL-U3 Settings .....	70
Using File > Save .....	72
Using Tools > Save Preferences .....	72
Using User Sets: Saving Settings to the CL-U3's Flash Memory .....	73
Ensuring Configuration Settings are not Overwritten .....	74
Saving the CL-U3 XML File to your Computer .....	74
<b>System Troubleshooting</b> .....	<b>75</b>
Troubleshooting Tips .....	75
Changing to the Backup Firmware Load .....	78
<b>Reference: Mechanical Drawings and Material List</b> .....	<b>79</b>
Mechanical Drawings .....	80
Enclosed Models .....	80
CL-U3B-IND OEM Board Set .....	82
CL-U3M-IND OEM Board Set .....	85
GPIO Board Assembly .....	88



Material List . . . . .	90
Using USB3 Vision Locking Cables with the Inverted Micro-B USB 3.0 Connector . . . . .	90
<b>Appendix: Timing for Camera Link Base/Medium Signals . . . . .</b>	<b>91</b>
Camera Link Signals . . . . .	92
Case 1: FVAL and LVAL are Level-Sensitive . . . . .	92
Case 2: FVAL and LVAL are Edge-Sensitive . . . . .	93
Case 3: FVAL is Edge-Sensitive and LVAL is Level-Sensitive . . . . .	94
Timing Values for All Cases . . . . .	95
<b>Reference: Mean Time Between Failures (MTBF) Data . . . . .</b>	<b>97</b>
<b>Reference: Regulatory Statements . . . . .</b>	<b>99</b>
United States & Canada . . . . .	100
European Union . . . . .	100
<b>Technical Support . . . . .</b>	<b>101</b>



# Chapter 1



## About this Guide

This chapter describes the purpose and scope of this guide, and provides a list of complementary guides.

The following topics are covered in this chapter:

- [“What this Guide Provides”](#) on page 2
- [“Documented Product Versions”](#) on page 2
- [“Related Documents”](#) on page 3
- [“Further Reading”](#) on page 3

## What this Guide Provides

This guide provides you with the information you need to connect the CL-U3 to Base or Medium Camera Link cameras.

In this guide you can find product overviews, instructions for connecting the cables, installing the Pleora eBUS™ SDK, establishing connections, performing general configuration tasks, and configuring the settings to properly capture and display images from Camera Link cameras. The last chapter of this guide provides Technical Support contact information for Pleora Technologies.

## Documented Product Versions

This guide covers the following product versions. The features and functionality documented in this guide may vary if you are using an earlier or later version of the product.

Table 2: Documented Product Versions

Product	Release/version documented in this guide...
iPORT CL-U3 External Frame Grabber	1.3.1
eBUS SDK and eBUS Player	6.1

## Related Documents

The *iPORT CL-U3 External Frame Grabber User Guide* is complemented by the following Pleora Technologies documents, which are available on the Pleora Technologies Support Center ([supportcenter.pleora.com](http://supportcenter.pleora.com)):

- *eBUS Player Quick Start Guide* and *eBUS Player User Guide*, available for Windows, Linux, and macOS
- *eBUS SDK API Quick Start Guides*, available for C++, .NET, Linux, and macOS
- *iPORT Advanced Features User Guide*
- *Configuring Your Computer and Network Adapters for Best Performance* knowledge base article
- *Introduction: Establishing a Serial Bridge* knowledge base article
- *Updating Pleora Firmware* knowledge base article

You can also consult the *eBUS SDK API Help Files*, which are installed on your computer during the installation of the eBUS SDK. You can access this documentation from the Windows Start menu under eBUS SDK.

## Further Reading

Although not required in order to successfully use the CL-U3, you can find details about industry-related standards and naming conventions in the following documents:

- *USB3 Vision Standard*, available from the Automated Imaging Association (AIA) at [www.visiononline.org](http://www.visiononline.org).
- *GenICam Standard Features Naming Convention* available from the European Machine Vision Association (EMVA) at [www.emva.org](http://www.emva.org).
- *Camera Link Standard, version 2.0* available from the Automated Imaging Association (AIA) at [www.visiononline.org](http://www.visiononline.org).
- *Pixel Format Naming Convention*, available from the European Machine Vision Association (EMVA) at [www.emva.org](http://www.emva.org).



# Chapter 2



## About the iPORT CL-U3 External Frame Grabber

This chapter describes the CL-U3 External Frame Grabber, including the models and key features.

The following topics are covered in this chapter:

- “Models” on page 6
- “Feature Set” on page 10
- “Key GenICam Features” on page 11
- “Available Pixel Formats” on page 12

## Models

The CL-U3 is available in several models and is equipped with the parts listed in the following tables. Before assembly, ensure that all components are included in the selected package.

Table 3: Models

Order code	Model	Quantity
903-0007	<b>iPORT CL-U3B External Frame Grabber in mountable enclosure</b> <i>Device Model Name: iPORT-CL-U3-PT03-CLOUPO1-128x</i>	
	iPORT CL-U3B External Frame Grabber <b>in mountable enclosure</b> for Camera Link Base mode. <b>Note:</b> No external power supply required.	1
903-0011	<b>iPORT CL-U3B Development Kit</b>	
	iPORT CL-U3B External Frame Grabber (903-0007) <b>Note:</b> No external power supply required.	1
	USB 3.0 cable	1
	eBUS SDK USB stick	1
903-0009	<b>iPORT CL-U3B-IND in mountable enclosure</b> <i>Device Model Name: iPORT-CL-U3-PT03-CLOUPO2-128x</i>	
	iPORT CL-U3B-IND External Frame Grabber <b>in mountable enclosure</b> for Camera Link Base mode (industrial use). <ul style="list-style-type: none"> <li>External power supply required. Order from Pleora Technologies using the following part numbers: 904-3905 or 930-1904.</li> </ul>	1



Table 3: Models (Continued)

903-0019	<b>iPORT CL-U3B-IND OEM board set</b> <i>Device Model Name: iPORT-CL-U3-PT03-CLOUP02-128x</i>	
	iPORT CL-U3B-IND External Frame Grabber <b>OEM board set</b> for Camera Link Base mode (industrial use). <ul style="list-style-type: none"><li>External power supply required. Order from Pleora Technologies using the following part numbers: 904-3905 or 930-1904.</li></ul>	1
	USB 3.0 cable	1
	eBUS SDK USB stick	1
903-0013	<b>iPORT CL-U3B-IND Development Kit</b>	
	iPORT CL-U3B-IND External Frame Grabber (903-0009) <b>Note:</b> External power supply required <i>and</i> supplied.	1
	Power supply	1
	USB 3.0 cable	1
	eBUS SDK USB stick	1
903-0008	<b>iPORT CL-U3M External in mountable enclosure</b> <i>Device Model Name: iPORT-CL-U3-PT03-CLOUP03-128x</i>	
	iPORT CL-U3M External Frame Grabber <b>in mountable enclosure</b> for Camera Link Medium mode. <b>Note:</b> No external power supply required.	1
903-0012	<b>iPORT CL-U3M Development Kit</b>	
	iPORT CL-U3M External Frame Grabber (903-0008) <b>Note:</b> No external power supply required.	1
	USB 3.0 cable	1
	eBUS SDK USB stick	1
903-0010	<b>iPORT CL-U3M-IND in mountable enclosure</b> <i>Device Model Name: iPORT-CL-U3-PT03-CLOUP04-128x</i>	
	iPORT CL-U3M-IND External Frame Grabber <b>in mountable enclosure</b> for Camera Link Medium mode (industrial use). <ul style="list-style-type: none"><li>External power supply required. Order from Pleora Technologies using the following part numbers: 904-3905 or 930-1904.</li></ul>	1

Table 3: Models (Continued)

903-0020	<b>iPORT CL-U3M-IND OEM board set</b> <i>Device Model Name: iPORT-CL-U3-PT03-CLOUP04-128x</i>	
	iPORT CL-U3M-IND External Frame Grabber <b>OEM board set</b> for Camera Link Medium mode (industrial use). <ul style="list-style-type: none"><li>External power supply required. Order from Pleora Technologies using the following part numbers: 904-3905 or 930-1904.</li></ul>	1

903-0014	<b>iPORT CL-U3M-IND Development Kit</b>	
	iPORT CL-U3M-IND External Frame Grabber (903-0010) <b>Note:</b> External power supply required <i>and</i> supplied.	1
	Power supply	1
	USB 3.0 cable	1
	eBUS SDK USB stick	1

The following table illustrates the product models that are available.

---

**CL-U3B:** Standard model of the enclosed, mountable CL-U3 for Camera Link Base cameras



---

**CL-U3B-IND:** Industrial model, available in mountable enclosure or as a board set for Camera Link Base cameras



---

**CL-U3M:** Standard model of the enclosed, mountable CL-U3 for Camera Link Medium cameras



---

**CL-U3M-IND:** Industrial model, available in mountable enclosure or as a board set for Camera Link Medium cameras



## Feature Set

	CL-U3B	CL-U3M	CL-U3B-IND	CL-U3B-IND	CL-U3M-IND	CL-U3M-IND
<b>Order code</b>	903-0007	903-0008	903-0009	903-0019	903-0010	903-0020
<b>Device Model Name</b>	iPORT-CL-U3-PT03-CLOUP01-128x	iPORT-CL-U3-PT03-CLOUP03-128x	iPORT-CL-U3-PT03-CLOUP02-128x		iPORT-CL-U3-PT03-CLOUP04-128x	
<b>Description</b>	Enclosed, standard use	Enclosed, standard use	Enclosed, industrial use	OEM board set, industrial use	Enclosed, industrial use	OEM board set, industrial use
<b>Camera Link mode</b>	<b>Base</b>	<b>Medium</b>	<b>Base</b>	<b>Base</b>	<b>Medium</b>	<b>Medium</b>
<b>Channels</b>	Single	Single	Single	Single	Single	Single
<b>MiniCL connectors</b>	1	2	1	1	2	2
<b>USB powered</b>	Yes	Yes	No	No	No	No
<b>PoCL</b>	No	No	Yes	Yes	Yes	Yes
<b>Operating temperature</b>	0 °C to 45 °C		<b>With PoCL off:</b> -40 °C to 60 °C <b>With PoCL on:</b> -40 °C to 58 °C	See note*	<b>With PoCL off:</b> -40 °C to 60 °C <b>With PoCL on:</b> -40 °C to 58 °C	See note*
<b>Storage temperature</b>	-40 °C to 85 °C					
<b>Dimensions (L x W x H) (mm)**</b>	45 x 83 x 51	45 x 83 x 51	45 x 83 x 51	45 x 52 x 37	45 x 83 x 51	45 x 52 x 37
<b>Weight (grams)</b>	Up to 137	Up to 137	Up to 137	Up to 42	Up to 137	Up to 42
<b>GPIO</b> LVDS/RS-422/HVTTL/±24V/ ±30V differential or TTL/LVCMOS single-ended inputs	—	—	2	2	2	2
TTL/LVCMOS single-ended inputs	4	4	2	2	2	2
TTL/LVCMOS single-ended outputs	3	3	3	3	3	3
<b>MTBF at 40 °C (hours)</b>	1,135,333	1,135,333	958,332	958,332	958,332	958,332
<b>Interface and transfer rate</b>	USB 3.0 interface with 3 Gb/s transfer rate					
<b>Standards compliance</b>	Compliant with Camera Link version 2.0 and USB3 Vision version 1.0					
<b>Regulatory compliance</b>	All enclosed units: FCC Part 15, subpart B, class B; CE; EN55032, EN55024; ICES-003; VCCI; RoHS2; REACH. All board sets: RoHS2; REACH.					
<b>Tap support</b>	Camera Link Base models: 1 and 2 taps. Camera Link Medium models: 1, 2, and 4 taps.					
<b>Pixel clock</b>	20 MHz to 85 MHz pixel clock					
<b>Frame buffer</b>	128 MB (120 MB is used for the frame buffer, 8 MB is used for the CL-U3 firmware)					
<b>Serial communication</b>	1 UART on Camera Link interface for serial control of cameras using a computer application over the USB 3.0 connection					

\*Case and junction temperature limits vary by IC device. For more information, see “Ambient and Junction Temperatures” on page 33.

\*\*Approximate, excluding 12-pin GPIO connector.

## Key GenICam Features

The CL-U3 supports the seven features mandated by the USB3 Vision standard, along with many additional features. The following table lists these mandatory features along with some of the key GenICam features. The full list of features can be seen in the Device Control dialog box of Pleora's eBUS Player application.

Table 4: Key GenICam Features

Feature	Description
DeviceScanType	Specifies the sensor scan type, such as areascan or linescan.
SensorDigitizationTaps	Specifies the number of digitized samples output simultaneously by the camera.
WidthMax	Specifies the maximum width of the image (in pixels).
HeightMax	Specifies the maximum height of the image (in pixels).
Width	Specifies the width of the image (in pixels).
Height	Specifies the height of the image (in pixels).
OffsetX	Specifies the horizontal image offset (in pixels).
OffsetY	Specifies the vertical image offset (in pixels).
PixelFormat	Specifies the format of the pixels provided by the camera.
CIConfiguration	This Camera Link specific feature describes the configuration used by the camera.
CIConnectorSelector	Selects the Camera Link interface to configure.
CSafePowerActive	Controls whether the SafePower protocol is active. SafePower is a protocol to prevent the CL-U3 from attempting to supply power to a conventional (non-PoCL) cable or camera.
CSafePowerStatus	Reports the status of the SafePower controller.

## Available Pixel Formats

The following table lists the pixel formats available on the CL-U3.



The CL-U3M and CL-U3M-IND are the only models that support 4 taps.

Table 5: Available Pixel Formats

CL-U3B CL-U3B-IND	CL-U3M CL-U3M-IND	Pixel Formats
1, 2 taps	1, 2, 4 taps	Mono8 (Default), Mono8s, Mono10, Mono10Packed, Mono12, Mono12Packed
1 tap	1 tap	Mono14, Mono16
1, 2 taps	1, 2, 4 taps	BayerGR8, BayerRG8, BayerGB8, BayerBG8
1, 2 taps	1, 2, 4 taps	BayerGR10, BayerRG10, BayerGB10, BayerBG10
1, 2 taps	1, 2, 4 taps	BayerGR12, BayerRG12, BayerGB12, BayerBG12
1, 2 taps	1, 2, 4 taps	BayerGR10Packed, BayerRG10Packed, BayerGB10Packed, BayerBG10Packed
1, 2 taps	1, 2, 4 taps	BayerGR12Packed, BayerRG12Packed, BayerGB12Packed, BayerBG12Packed
1 tap	1 tap	BayerGR16, BayerRG16, BayerGB16, BayerBG16
1 tap	1 tap	RGB8, BGR8
No*	1 tap	RGB10
No*	1 tap	RGB12
1, 2 taps	1, 2, 4 taps	SCF1WGWR8
1, 2 taps	1, 2, 4 taps	SCF1WGWR10
1, 2 taps	1, 2, 4 taps	SCF1WGWR12
1 tap	1 tap	SCF1WGWR14
1,2 taps	1,2 taps	YUV411_8_UYYVY**
1 tap	1 tap	YUV422_8_UYVY**
1 tap	1 tap	YUV8_UYV**
1 tap	1 tap	YCbCr422_8_CbYCrY**
1,2 taps	1,2 taps	YCbCr709_411_8_CbYYCrY**
1 tap	1 tap	YCbCr709_422_8_CbYCrY**

\*Indicates unavailable pixel format.

\*\* Available in release 1.3.1 (and later) of the CL-U3.

# Chapter 3



## CL-U3 Connections

This chapter describes the CL-U3 connections, including connector details and pinout information. It also includes information about how the CL-U3 receives power through either the Micro-B USB3 connector or an external power supply, depending on the product model you are using.

When the CL-U3 is powered, you can observe the status LEDs.

The following topics are covered in this chapter:

- “[Connector and Switch Locations](#)” on page 14
- “[Micro-B USB 3.0 Connector](#)” on page 16
- “[Camera Link Connectors](#)” on page 17
- “[Mapping of Camera Link Connector and 12-Pin GPIO Connector Inputs](#)” on page 18
- “[12-Pin GPIO Connector](#)” on page 19
- “[Differential Type and I/O Level Switches](#)” on page 22
- “[Powering the CL-U3](#)” on page 26
- “[Power Consumption](#)” on page 28
- “[Status LEDs](#)” on page 30

# Connector and Switch Locations

The following figures and table describe the CL-U3 connectors and switches.

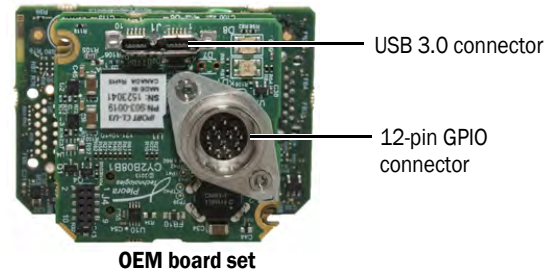
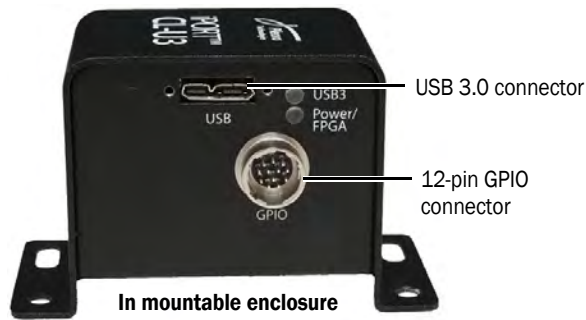
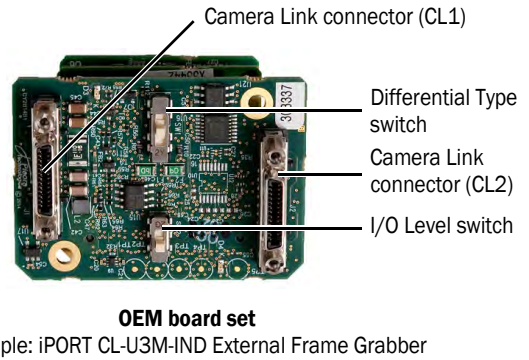
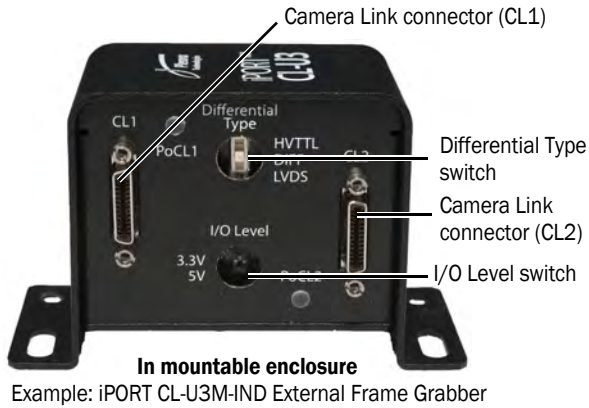

Depending on your product model, some connectors and switches may not be available.

Table 6: Connectors and Switches

Component	Type	Description
USB connector	Micro-B USB 3.0 connector	Connects a computer to the CL-U3 using a USB3 Vision connection. Compatible with USB 3.0 (SuperSpeed) connections. For the standard models, supports power over USB 3.0. For more information, see <a href="#">“Micro-B USB 3.0 Connector”</a> on page 16.
GPIO connector	12-pin circular connector	For the standard models, provides external signals, such as GPIO, to the CL-U3. For the industrial models, provides power and also provides I/O signals to the CL-U3. For more information, see <a href="#">“12-Pin GPIO Connector”</a> on page 19.

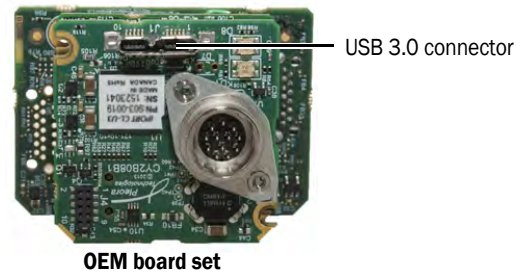

Table 6: Connectors and Switches (Continued)

Component	Type	Description
CL1 connector	Miniature Camera Link (MiniCL) connector	<p>Provides connection to a Camera Link Base or Medium camera. Serial communication on this connector is mapped to the Bulk0 serial communication interface of the CL-U3.</p> <p>This connector corresponds to Connector 1, as outlined in the <i>Camera Link Standard</i>.</p> <p>When PoCL is enabled, the industrial models can supply 4 W at 12 V to each Camera Link connector, as outlined in the <i>Camera Link Standard</i>.</p> <p>For more information, see “<a href="#">Camera Link Connectors</a>” on page 17.</p>
CL2 connector	<p>Miniature Camera Link (MiniCL) connector</p> <p>Available only on the Camera Link Medium models</p>	<p>Provides connection to a Camera Link Medium camera to transmit images to the CL-U3, using two Camera Link cables.</p> <p>This connector corresponds to Connector 2, as outlined in the <i>Camera Link Standard</i>.</p> <p>When PoCL is enabled, the CL-U3M-IND can supply 4 W at 12 V to the camera, as outlined in the <i>Camera Link Standard</i>.</p> <p>For more information, see “<a href="#">Camera Link Connectors</a>” on page 17.</p>
Differential Type switch	<p>3-position DIP switch</p> <p>Available only on the industrial models</p>	<p>Selects the termination type for differential inputs.</p> <p>For more information, see “<a href="#">Differential Type and I/O Level Switches</a>” on page 22.</p>
I/O Level switch	2-position DIP switch	<p>Selects the voltage for single-ended GPIO inputs and outputs (3.3 V or 5 V).</p> <p>For more information, see “<a href="#">Differential Type and I/O Level Switches</a>” on page 22.</p>

## Micro-B USB 3.0 Connector

The CL-U3 uses a Micro-B USB 3.0 connector for communication with your computer. For the standard models, it also supplies power to the CL-U3.



For the industrial models, we recommend that you apply external power to the CL-U3 BEFORE you connect it to a USB port to ensure that adequate power is available.



The CL-U3 uses a USB 3.0 Micro-B connector in an inverted configuration. For information about using locking cables with the inverted configuration, see [“Using USB3 Vision Locking Cables with the Inverted Micro-B USB 3.0 Connector”](#) on page 90.

### Locking Connectors

The CL-U3 supports the Micro-B locking connectors specified by the *USB3 Vision Standard*. The enclosed CL-U3 models include threaded screw holes that comply with the connectors specified in the standard.



Use a USB3 Vision cable and ensure that you secure the cable to the Micro-B USB 3.0 connector using the supplied locking screws.

## Camera Link Connectors

The CL-U3 supports Base or Medium Camera Link cameras (depending on your product model), which stream image data to the CL-U3.

For the Camera Link Base models (the CL-U3B and CL-U3B-IND), the CL1 connector is used to connect a Camera Link camera to the CL-U3 using one standard Camera Link cable, as outlined in the *Camera Link Standard*. This connector can process up to 24 bits of data from the camera.

For the Camera Link Medium models (the CL-U3M and CL-U3M-IND), the CL1 and CL2 connectors are used to connect a Camera Link camera to the CL-U3 using two standard Camera Link cables, as outlined in the *Camera Link Standard*. These connectors can process up to 48 bits of data from the camera.

All models provide the following Camera Link control signals on the CL1 connector, as outlined in the *Camera Link Standard*: CC1, CC2, CC3, and CC4.

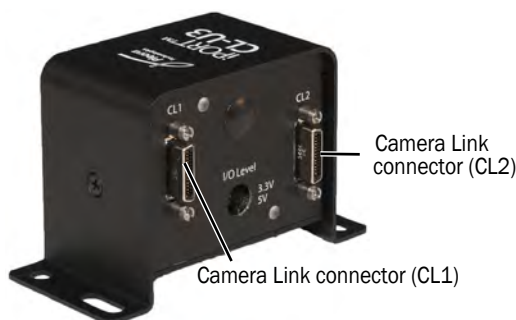

**In mountable enclosure**  
Example: iPORT CL-U3M External Frame Grabber

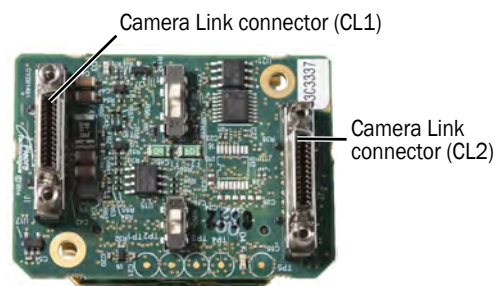

**OEM board set**  
Example: iPORT CL-U3M-IND External Frame Grabber

### Powering a Camera using Power Over Camera Link (PoCL)

The industrial models, which are powered through an external power supply, can optionally supply power to the camera using PoCL, in accordance to the *Camera Link Standard*.

When powered using PoCL, the CL-U3B-IND can provide up to 4 W at 12 V to compatible cameras through the Camera Link connector, while the CL-U3M-IND can provide up to a maximum of 8 W.



To enable PoCL and to prevent the CL-U3 from attempting to supply power to a non-PoCL cable or camera, you must enable the **CISafePowerActive** feature using eBUS Player (or an application created with the eBUS SDK). For more information, see “[Enabling SafePower and PoCL](#)” on page 59.

When power is being supplied to the camera using PoCL, the **PoCL1** and/or **PoCL2** status LEDs will be on. For more information about the status LEDs, see “[Status LEDs](#)” on page 30.

## Voltage Drop Monitoring

The CL-U3 includes a **Voltage Dropped** state that monitors a voltage drop from 12 V to a voltage below 10.5 V for cameras using PoCL. If the voltage drops below 10.5 V for more than 20 ms, the CL-U3 returns to the **PoCL Sensing** state.

For information about viewing the SafePower status and the status changes that occur, including **PoCL Sensing**, see “[Enabling SafePower and PoCL](#)” on page 59.

## Mapping to the Serial Communication Interface

The CL1 Camera Link connector is mapped to the Bulk0 serial communication interface on the CL-U3.

# Mapping of Camera Link Connector and 12-Pin GPIO Connector Inputs

The GPIO pins on the 12-pin GPIO connector allow an external signal to control a Camera Link camera, and are typically used for triggering. For example, you can use a trigger to synchronize image capture from multiple cameras or to synchronize image capture with an external device.

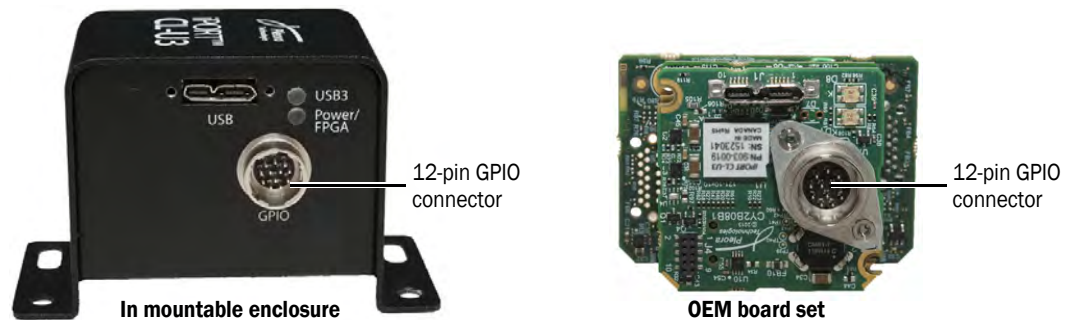

Using the Programmable Logic Controller (PLC), you can map and modify the GPIO input signals (GPIO\_IN3, GPIO\_IN2, GPIO\_IN1, and GPIO\_IN0) to:

- the camera control output signals (CC1, CC2, CC3, CC4) on the CL1 connector; and
- the GPIO output signals (GPIO\_OUT2, GPIO\_OUT1, GPIO\_OUT0) on the 12-pin GPIO connector.

There are 16 possible mappings of the GPIO signals. For more information, see “[Handling GPIO, Camera Control, and PLC Input and Output Programming Signals](#)” on page 35.

## 12-Pin GPIO Connector

The GPIO inputs and outputs on the 12-pin GPIO connector support a variety of differential and single-ended inputs and outputs, such as HVTTL, LVDS, and LVC MOS. The available inputs and outputs vary, depending on your CL-U3 model.

Table 7: Summary of Available Signals on the 12-Pin GPIO Connector

	CL-U3B and CL-U3M (standard models)	CL-U3B-IND and CL-U3M-IND (industrial models)
Differential LVDS/RS-422/HVTTL/ $\pm 24$ V/ $\pm 30$ V inputs (Can optionally be used as single-ended TTL/LVC MOS inputs)	N/A	2
Single-ended TTL/LVC MOS inputs	4	2
Single-ended TTL/LVC MOS outputs	3	3

## 12-Pin GPIO Connector Pinouts – Standard Models

The pinouts for the 12-pin GPIO connector on the standard models (CL-U3B and CL-U3M) are listed in the following table.

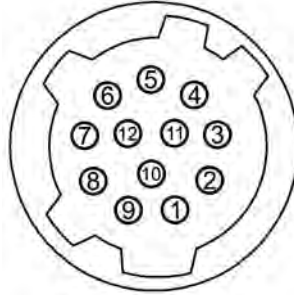

The manufacturer and part number are provided in “[Material List](#)” on page 90.

The mating connector is a Hirose 12-pin circular connector, part number HR10A-10P-12S(73).

Table 8: 12-Pin GPIO Connector Pinouts – CL-U3B and CL-U3M

Pin	Function	Type	PLC signal	Notes
1	Reserved	Reserved	N/A	Reserved, no connection
2	Reserved	Reserved	N/A	Reserved, no connection
3	GPIO_IN3	Single-ended input	GpioIn3	
4	GPIO_OUT2	Single-ended output	GpioOut2	
5	GND/EMI_GND	Ground	N/A	Signal ground
6	GPIO_IN2	Single-ended input	GpioIn2	
7	GPIO_OUT1	Single-ended output	GpioOut1	
8	GPIO_IN1	Single-ended input	GpioIn1	
9	GPIO_OUT0	Single-ended output	GpioOut0	
10	GPIO_IN0	Single-ended input	GpioIn0	
11	Reserved	Reserved	N/A	Reserved, no connection
12	Reserved	Reserved	N/A	Reserved, no connection

## 12-Pin GPIO Connector Pinouts – Industrial Models

The pinouts for the 12-pin GPIO connector on the industrial models (CL-U3B-IND and CL-U3M-IND) are listed in the following table.

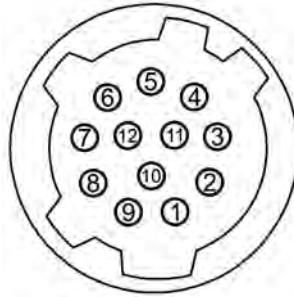

The manufacturer and part number are provided in “[Material List](#)” on page 90.

The mating connector is a Hirose 12-pin circular connector, part number HR10A-10P-12S(73).

Table 9: 12-Pin GPIO Connector Pinouts: CL-U3B-IND and CL-U3M-IND

Pin	Function	Type	PLC signal	Notes
1	RET	Power return	N/A	Ground
2	VIN	Power input	N/A	Protected by 600 W @ 1.0 ms PP Zener TVS, +/- 30 kV per KBM. Receives 11.6 V to 13 V unfiltered DC input, up to 1.1 A.
3	GPIO_IN1-	Differential input1 negative	GpioIn1	Do not connect for single-ended operation. Pin 6 provides the single-ended connection.
4	GPIO_OUT2	Single-ended output	GpioOut2	
5	GND/EMI_GND	Ground		Signal ground
6	GPIO_IN1+	Differential input1 positive	GpioIn1	Can be used as a single-ended input (optional).
7	GPIO_OUT1	Single-ended output	GpioOut1	
8	GPIO_IN0-	Differential input0 negative	GpioIn0	Do not connect for single-ended operation. Pin 10 provides the single-ended connection.
9	GPIO_OUT0	Single-ended output	GpioOut0	
10	GPIO_IN0+	Differential input0 positive	GpioIn0	Can be used as a single-ended input (optional).
11	GPIO_IN3	Single-ended input	GpioIn3	
12	GPIO_IN2	Single-ended input	GpioIn2	

## Differential Type and I/O Level Switches

The Differential Type switch (on the industrial models) and I/O Level switch (on all models) are used to configure the CL-U3 to work with single-ended and differential inputs.

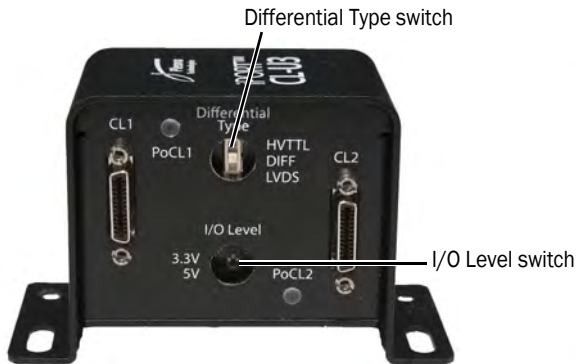

**In mountable enclosure**

Example: iPORT CL-U3M-IND External Frame Grabber

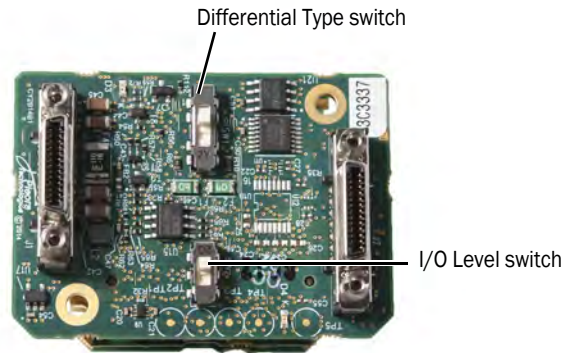

**OEM board set**

Example: iPORT CL-U3M-IND External Frame Grabber



### Warning:

To avoid damage to the CL-U3 and connected equipment (or reduced lifetime of the **Differential Type** switch), ensure you observe the following precautions:

- Set the **Differential Type** and **I/O Level** switches **BEFORE** you connect equipment and apply power to the CL-U3.
- Do not set the **Differential Type** switch to **HVTTL** when you are using LVDS equipment.
- Do not change the **Differential Type** switch setting while the CL-U3 is powered or while devices are connected.



The **Differential Type** switch, which is available on the industrial models, is used to select the differential and single-ended signal levels.

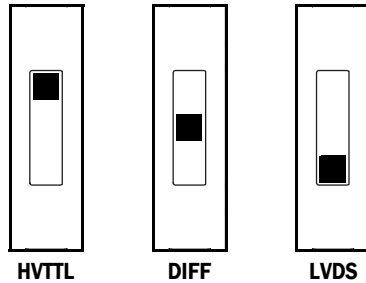

The **I/O Level** switch is used to select either 3.3 V LVCMOS or 5 V TTL operation, and is used with single-ended inputs and outputs.

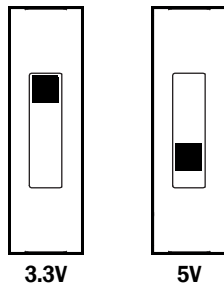

The following table shows how the **Differential Type** and **I/O Level** switches can be set, based on the input type.

Table 10: Switch Settings Based on Input Type

	Input/output type	Set the Differential Type switch to...	Set the I/O Level switch to...
Single-ended inputs and outputs	LVCMOS	DIFF	3.3 V
	TTL	DIFF	5 V
	HVTTL/HVCMOS/HTL	HVTTL	N/A
Differential inputs	LVDS	LVDS	N/A
	RS-422	LVDS or DIFF	N/A
	+/-24 V or +/-30 V	DIFF	N/A

## Differential and Single-Ended Input/Output Specifications

The input and output specifications vary, depending on how the **Differential Type** and **I/O Level** switches are set, as listed in the following tables.



### Warning:

To avoid damage to the CL-U3 and connected equipment (or reduced lifetime of the **Differential Type** switch), ensure you observe the following precautions:

- Set the **Differential Type** and **I/O Level** switches **BEFORE** you connect equipment and apply power to the CL-U3.
- Do not set the **Differential Type** switch to **HVTTL** when you are using LVDS equipment.
- Do not change the **Differential Type** switch setting while the CL-U3 is powered or while devices are connected.

Table 11: GPIO Differential Input Specifications

Specifications	Input type				
	Differential +/-24 V, +/-30 V, RS-422	Differential LVDS, RS-422 with 100 Ohm termination	Differential used as single-ended HVTTL/HVCMOS	Differential used as single-ended LVCMOS	Differential used as single-ended TTL
Differential input termination	10 K and 50 pF in series	100 Ohm	N/A	N/A	N/A
<b>Single-ended input termination</b> Negative (-) input	47 K to 1/3 of I/O level (1.1 V for 3.3 V I/O level or 1.7 V for 5 V I/O level)		Do not connect to negative (-) input		
Positive (+) input	100 K to CL-U3 GND				
<b>Input thresholds</b> Low	-200 mV (minimum), differential -50 mV (typical), differential 0 mV (maximum), differential		<6.5 V	<0.9 V	<1.5 V
High	+200 mV (maximum), differential +50 mV (typical), differential 0 mV (minimum), differential		>9.5 V	>1.3 V	>1.9 V
Hysteresis	150 mV (typical)				
Maximum delay	100 nsec	65 nsec	100 nsec	100 nsec	100 nsec
Minimum operation voltage	-30 V				
Maximum operation voltage	+30 V				

Table 11: GPIO Differential Input Specifications (Continued)

Specifications	Input type				
	Differential +/-24 V, +/-30 V, RS-422	Differential LVDS, RS-422 with 100 Ohm termination	Differential used as single-ended HVTTTL/HVCMOS	Differential used as single-ended LVCMOS	Differential used as single-ended TTL
Clamping voltage	Below -42 V, over +42 V				
ESD protection	Up to class -4 (+/-15 kV)				
EMI filtering	Serial ferrite bead 120 Ohm @ 100 MHz				

Table 12: GPIO Single-Ended Input Specifications

Specifications	Input type	
	LVCMOS	TTL
Termination	100 K to CL-U3 GND	
Low threshold	<0.8 V	<1.5 V
High threshold	>2.0 V	>3.5 V
Maximum delay	8 nsec	
Minimum voltage	-0.5 V (absolute)	
Maximum voltage	6.5 V (absolute)	
ESD protection	Up to class -4 (+/-15 kV)	
EMI filtering	Serial ferrite bead 120 Ohm @ 100 MHz	

Table 13: GPIO Output Specifications

Specifications	Output type	
	LVCMOS	TTL
High level output current	+/-24 mA	+/-32 mA
<b>Output Voltage</b>		
High minimum	2.4 V (@24 mA)	3.8 V (@ 32 mA)
High maximum	3.5 V	5.3 V
Low maximum	0.55 V (@24 mA)	0.55 V (@ 32 mA)
Maximum delay	6.4 nsec	
ESD protection	Up to class -4 (+/-15 kV)	
EMI filtering	Serial ferrite bead 120 Ohm @ 100 MHz	

## Powering the CL-U3

Depending on the product model, you can power the CL-U3 in one of the following ways:

- **Standard models (CL-U3B and CL-U3M).** Powered using a USB 3.0 connection.
- **Industrial models (CL-U3B-IND and CL-U3M-IND).** Powered using an external power supply.

### Powering the CL-U3B and CL-U3M Using USB 3.0

For the standard models, a USB 3.0 connection powers the CL-U3.

To power the CL-U3 over a USB 3.0 connection, 900 mA is required from the USB 3.0 port. Although 900 mA may not always be used, it is requested from the port.



If the host controller manages multiple ports and there are other devices that draw a large amount of power (for example, another USB3 Vision device or a hard drive), the host controller may not grant the requested 900 mA, resulting in dropped images, dropped connection, or failure to connect. Similarly, on a USB hub, ensure 900 mA is available for the port.



#### Important Power Sequence Information

To avoid damage to the CL-U3 (and in some cases the connected equipment):

- If you are using GPIO inputs, set the **Differential Type** and **I/O Level** switches BEFORE you connect equipment and BEFORE you apply power to the CL-U3.
- Always power up the CL-U3 BEFORE the camera.
- Always power down the camera BEFORE the CL-U3.

#### To power the [CL-U3B](#) and [CL-U3M](#) using USB 3.0

1. Ensure that the Camera Link camera and the CL-U3 are NOT receiving power.

2. Securely connect the Camera Link cable to the camera and the CL-U3.

Ensure that you tighten the screws to prevent the camera from being disconnected accidentally.

**Important:** Do not disconnect the Camera Link cable while the camera or CL-U3 are receiving power.

3. Connect the CL-U3 to a USB 3.0 port on your computer using a USB 3.0 cable.

4. Apply power to the camera using a power supply.

**Important:** The camera's ground must be electrically floating or attached to a power supply that uses the same ground as other attached USB 3.0 devices, such as the computer or a USB 3.0 hub.

## Powering the CL-U3B-IND and CL-U3M-IND Using an External Power Supply

For the industrial models, power is supplied to the CL-U3 through the 12-pin GPIO connector with a compatible power supply. For proper operation with both PoCL and non-PoCL cameras, 11.6 V to 13 V is required, with a minimum of 1.1 A.

### External Power Supply – Input Signals

The following table lists the input power signals for the CL-U3B-IND and CL-U3M-IND from an external power supply using the 12-pin GPIO connector.

Table 14: Input Signals from the 12-Pin GPIO Connector

Name	Volts (V)	Notes
VIN	11.6-13V	Efficiency of power circuitry (including drops on Schottky diodes) is flat in this range. Unfiltered DC power from an external power supply through the 12-pin GPIO connector. Reverse voltage protected, up to -30 VDC. The CL-U3B-IND and CL-U3M-IND generate all internal power rails from the VIN signal. A resident common mode filter allows the input to be unfiltered, directly from a switching wall plug power supply.
RET	Ground	Ground for VIN.
GND	Ground	0 V relative to other voltages on the CL-U3B-IND and CL-U3M-IND.



#### Important Power Sequence Information

To avoid damage to the CL-U3 (and in some cases the connected equipment):

- If you are using GPIO inputs, set the **Differential Type** and **I/O Level** switches **BEFORE** you connect equipment and **BEFORE** you apply power to the CL-U3.
- Always power up the CL-U3 **BEFORE** the camera.
- Always power down the camera **BEFORE** the CL-U3.



We recommend that you apply external power to the CL-U3 **BEFORE** you connect it to a USB port.

## To power the [CL-U3B-IND](#) and [CL-U3M-IND](#) using an external power supply

1. Ensure that the Camera Link camera and the CL-U3B-IND/CL-U3M-IND are **NOT** receiving power.
2. Securely connect the Camera Link cable to the camera and to the CL-U3B-IND/CL-U3M-IND3. Ensure that you tighten the screws to prevent the camera from being disconnected accidentally.
3. Supply 12 V power to the 12-pin GPIO connector on the CL-U3B-IND/CL-U3M-IND3.  
**Important:** The 12 V power supply must use the same ground as other attached USB 3.0 devices, for example, the computer or a USB 3.0 hub.
4. Connect the CL-U3B-IND/CL-U3M-IND to the computer using a USB 3.0 cable.
5. Apply power to the camera:
  - If you plan on powering the camera using PoCL, use eBUS Player to enable PoCL (using the **CLSafePowerActive** feature). For more information, see [“Enabling SafePower and PoCL”](#) on page 59.
  - If you are not powering the camera using PoCL, connect the camera to a power supply.

## Power Consumption

The tables in this section outline the power consumption of the CL-U3. The measurements are based on the use of the CL-U3 streaming video from the Vivid Engineering Camera Link Simulator CLS-212.

Table 15: CL-U3B Using Power from USB 3.0 Port

Pixel clock frequency (MHz)	Sensor digitization taps	Width	Height	Pixel format	Data rate (Mbps)	Power (W)
20	2	4096	4096	Mono12Packed	476	1.7
85	2	4096	4096	Mono12Packed	2024	2.1

Table 16: CL-U3M Using Power from USB 3.0 Port

Pixel clock frequency (MHz)	Sensor digitization taps	Width	Height	Pixel format	Data rate (Mbps)	Power (W)
20	4	4096	4096	Mono8	630	1.7
85	4	4096	4096	Mono8	2543	2.3

Table 17: CL-U3B-IND Power Consumption using External Power Supply\*

Pixel clock frequency (MHz)	Sensor digitization taps	Width	Height	Data rate (Mbps)	External power supply	Bus measurement	Total (W)
					Power (W)	Power (W)	
20	2	4096	4096	476	0.9	1.0	1.9
85	2	4096	4096	2024	1.2	1.1	2.3

\*Using the Mono12Packed pixel format, with PoCL disabled.

Table 18: CL-U3M-IND using External Power Supply\*\*

Pixel clock frequency (MHz)	Sensor digitization taps	Width, height	Height	Data rate (Mbps)	External power supply	Bus measurement	Total (W)
					Power (W)	Power (W)	
20	4	4096	4096	630	0.93	1.01	1.94
85	4	4096	4096	2543	1.16	1.14	2.30

\*\*Using the Mono8 pixel format, with PoCL disabled.

## Status LEDs

The CL-U3 has status LEDs that indicate the operating status of the CL-U3's USB controller, the connection between the CL-U3 and the host computer, power, and firmware, as described in the following figures and table.

For the industrial models, additional LEDs located beside the Camera Link connectors show the PoCL status.

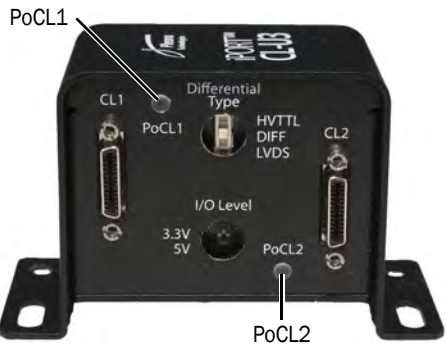

**In mountable enclosure**

Example: iPORT CL-U3M-IND External Frame Grabber



**In mountable enclosure**

All models

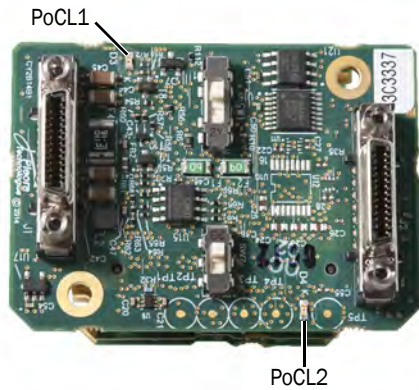

**OEM board set**

Example: iPORT CL-U3M-IND External Frame Grabber



**OEM board set**

All models



Not all LEDs will be available, depending on your product model.



Table 19: Status LEDs

LED	Description
Power/FPGA	<p><b>Green:</b> The CL-U3 is receiving power and the main firmware load is being used.</p> <p><b>Green and orange:</b> The CL-U3 is receiving power and the backup firmware load is being used. For the industrial models, it can also indicate that you have not connected the USB cable to the computer.</p> <p><b>Off:</b> The CL-U3 is not receiving power.</p>
USB3	<p><b>Yellow (flashing quickly):</b> The CL-U3 is operating properly.</p> <p><b>Yellow (flashing):</b> Indicates GenCP traffic between the CL-U3 and the host.</p> <p><b>Green (solid):</b> A SuperSpeed (USB 3.0) connection has been established.</p> <p><b>Off:</b> A USB 2.0 connection has been established.</p>
PoCL1, PoCL2 (available on the industrial models)	<p><b>Green:</b> Power over Camera Link (PoCL) is active and the camera is being powered using PoCL.</p> <p><b>Off:</b> The camera is not receiving power through PoCL.</p>



# Chapter 4



## Ambient and Junction Temperatures

This chapter provides you with the information you need to ensure the optimal operating temperature for your CL-U3B-IND and CL-U3M-IND OEM board set.



You should store the CL-U3 at temperatures between -40°C to +85°C.

This chapter lists the components that consume the largest amount of power on the CL-U3 OEM board set, and will therefore be most affected by high temperatures. You must provide a method to cool these components using a heat sink or thermal pad.

Table 20: Thermal Guidelines, CL-U3B-IND and CL-U3M-IND OEM Board Set

Reference designator and location	Component and manufacturer part number	Rating for component on standard Pleora product*
U1, USB PHY board	Cypress ARM9 USB3 Controller <b>Part number:</b> CYUSB3014-BZXI	<b>Ambient (under bias):</b> -40°C to +85°C <b>Junction:</b> Not specified <b>Case:</b> Not specified <b>Junction-to-case thermal resistance <math>\Theta_{JC}</math>:</b> Not specified <b>Junction-to-ambient thermal resistance <math>\Theta_{JA}</math>:</b> Not specified <b>Power consumption:</b> ~450 mW
U2, FPGA board	ISSI DDR3 <b>Part number:</b> IS43TR16640A-15GBLI	<b>Ambient:</b> Not specified <b>Junction:</b> Not specified <b>Case:</b> -40°C to +95°C <b>Junction-to-case thermal resistance <math>\Theta_{JC}</math>:</b> Not specified <b>Junction-to-ambient thermal resistance <math>\Theta_{JA}</math>:</b> Not specified <b>Power consumption:</b> ~ 260 mW at 2.5Gbps streaming

Table 20: Thermal Guidelines, CL-U3B-IND and CL-U3M-IND OEM Board Set (Continued)

Reference designator and location	Component and manufacturer part number	Rating for component on standard Pleora product*
U1, FPGA board	Altera FPGA  <b>Part number:</b> 5CEFA4U19I7N	<b>Ambient:</b> Not specified <b>Junction:</b> -40°C to +100°C <b>Case:</b> Not specified <b>Junction-to-case thermal resistance <math>\Theta_{JC}</math>:</b> 5 (°C/W) <b>Junction-to-ambient thermal resistance <math>\Theta_{JA}</math>:</b> <ul style="list-style-type: none"> <li>• <b>Still air:</b> 23.6 (°C/W)</li> <li>• <b>100 ft./min:</b> 19.5 (°C/W)</li> <li>• <b>200 ft./min:</b> 17.5 (°C/W)</li> <li>• <b>400 ft./min:</b> 15.9 (°C/W)</li> </ul> <b>Power consumption:</b> ~ 880 mW

\*  $\Theta_{JC} = (T_j - T_a) / P_{top}$ , where  $P_{top}$  = Power dissipation from the top of the package.

$\Theta_{JA} = (T_c - T_a) / P$ , where P = Total power dissipation.

# Chapter 5



## Handling GPIO, Camera Control, and PLC Input and Output Programming Signals

The CL-U3 includes a programmable logic controller (PLC) that lets you control external machines and react to inputs. By controlling your system using the PLC, you can make functional changes, adjust timing, or add features without having to add new hardware.

If your system includes a quadrature encoder, you can process its signals and produce trigger signals for the camera using the CL-U3's PLC, as described later in this chapter.



For an introduction to the PLC and for detailed information about how PLC signals are handled, see the *iPORT Advanced Features User Guide*, available on the Pleora Support Center at [supportcenter.pleora.com](http://supportcenter.pleora.com).

The following topics are covered in this chapter:

- “PLC Input and Output Programming Signals” on page 36
- “Using Quadrature Encoders” on page 38
- “Differential Connection” on page 39
- “Single-Ended Connection” on page 39
- “Processing Quadrature Encoder Signals” on page 40

## PLC Input and Output Programming Signals

The following table lists the PLC input and output programming signals and indicates the pins on which they are available.

Table 21: PLC Signal Usage

Signal name	PLC equation usage	Associated pin on the 12-pin GPIO connector	Camera Link connector
PbOFval	In	No associated pin	
PbOLval	In	No associated pin	
PbODval	In	No associated pin	
PbOSpare	In	No associated pin	
GpioIn0	In	<b>Standard models:</b> Pin 10 (GPIO_IN0) <b>Industrial models*:</b> Pin 10 (GPIO_IN0+) and 8 (GPIO_IN0-)	
GpioIn1	In	<b>Standard models:</b> Pin 8 (GPIO_IN1) <b>Industrial models*:</b> Pin 6 (GPIO_IN1+) and 3 (GPIO_IN1-)	
GpioIn2	In	<b>Standard models:</b> Pin 6 (GPIO_IN2) <b>Industrial models*:</b> Pin 12 (GPIO_IN2)	
GpioIn3	In	<b>Standard models:</b> Pin 3 (GPIO_IN3) <b>Industrial models*:</b> Pin 11 (GPIO_IN3)	
BufferWM0	In	No associated pin	
Grb0AcqActive	In	No associated pin	
PlcCtrl0	In	No associated pin	
PlcCtrl1	In	No associated pin	
PlcCtrl2	In	No associated pin	
PlcCtrl3	In	No associated pin	
PbOCC0	In, out	No associated pin	CC1
PbOCC1	In, out	No associated pin	CC2
PbOCC2	In, out	No associated pin	CC3
PbOCC3	In, out	No associated pin	CC4
GpioOut0	In, out	Pin 9 on all models (GPIO_OUT0)	
GpioOut1	In, out	Pin 7 on all models (GPIO_OUT1)	
GpioOut2	In, out	Pin 4 on all models (GPIO_OUT2)	
PlcFval0	In, out	No associated pin	

Table 21: PLC Signal Usage (Continued)

Signal name	PLC equation usage	Associated pin on the 12-pin GPIO connector	Camera Link connector
PlcLval0	In, out	No associated pin	
PlcMval0	In, out	No associated pin	
PlcTrig0	In, out	No associated pin	
PlcTimestampCtrl	In, out	No associated pin	
Timer0Trig	In, out	No associated pin	
Timer0Out	In	No associated pin	
Timer1Trig	In, out	No associated pin	
Timer1Out	In	No associated pin	
Timer2Trig*	In, out	No associated pin	
Timer2Out*	In	No associated pin	
Timer3Trig*	In, out	No associated pin	
Timer3Out*	In	No associated pin	
Counter0Reset	In, out	No associated pin	
Counter0Inc	In, out	No associated pin	
Counter0Dec	In, out	No associated pin	
Counter0Eq	In	No associated pin	
Counter0Gt	In	No associated pin	
Counter1Reset	In, out	No associated pin	
Counter1Inc	In, out	No associated pin	
Counter1Dec	In, out	No associated pin	
Counter1Eq	In	No associated pin	
Counter1Gt	In	No associated pin	
Rescaler0In	In, out	No associated pin	
Rescaler0Out	In	No associated pin	
Delayer0In	In, out	No associated pin	
Delayer0Out	In	No associated pin	
Event0	In, out	No associated pin	
Event1	In, out	No associated pin	
Event2	In, out	No associated pin	
Event3	In, out	No associated pin	

\* Available in release 1.3.1 (and later) of the CL-GigE firmware.

\*For the full list of industrial models, see “Models” on page 6.

## Using Quadrature Encoders

Quadrature encoder sensors produce electrical signals that indicate the direction, speed, and motion of the processed material on the web or conveyor systems. These signals are often used to control camera triggering to provide uniform images under varying load conditions. The quadrature encoder’s signals are typically processed by an external frame grabber that produces a trigger signal for the camera.

Quadrature encoders have a solid or hollow shaft that is mechanically connected to a motor or rotating apparatus on the web or conveyor system. Two-phase quadrature encoders have two outputs labeled **A** and **B**, which produce square wave signals when the shaft is rotating. These signals are 90° out-of-phase. When the shaft changes rotation between clockwise and counter-clockwise directions, these signals change phasing between +90° and -90°.

Figure 1: Two-Phase Quadrature Encoder Signals

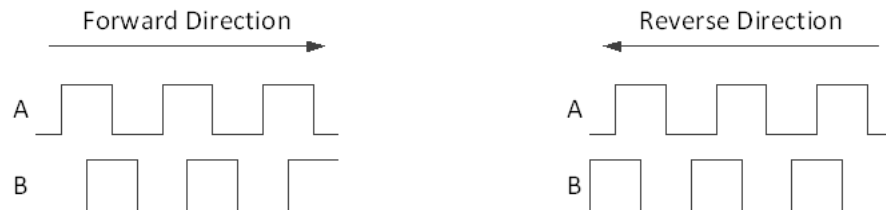

This change is used to detect direction of motion. The rate of the square wave signals is proportional to the rotation speed of the shaft. This change is also used for detecting speed of motion. When these signals are steady-state, and are not producing square wave signals, the motion has stopped.



For information about the electrical interface on the CL-U3, see “Differential Type and I/O Level Switches” on page 22.



## Differential Connection

The following diagram illustrates a typical differential connection to a quadrature encoder.

Figure 2: Typical Differential Connection to Quadrature Encoder

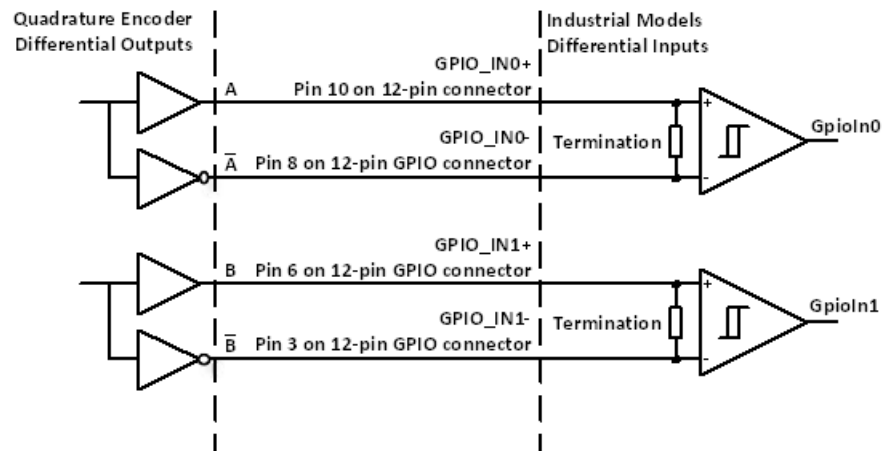

## Single-Ended Connection

The following diagram illustrates a typical single-ended connection to a quadrature encoder.

Figure 3: Typical Single-Ended Differential Connection to Quadrature Encoder

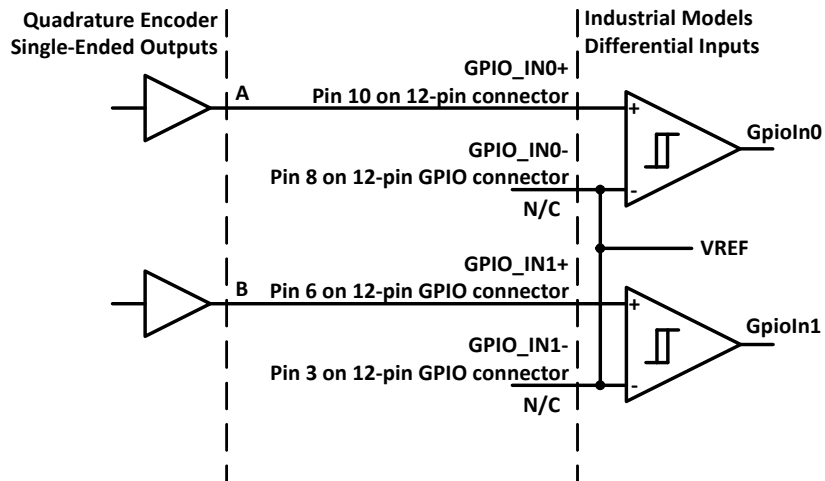

## Processing Quadrature Encoder Signals

This section provides an example of how you can using the CL-U3's PLC to process signals from a quadrature encoder.

**Example:** Connect **GpioIn0** and **GpioIn1** to quadrature encoder outputs **A** and **B**, respectively.

In this example, images are captured only when the conveyor belt or web is moving in the forward direction. When the conveyor belt or web moves in the forward direction, signal **A** leads signal **B** by 90°. When the conveyor belt moves in the reverse direction, signal **A** lags signal **B** by 90°. The PLC provides a trigger signal on the Camera Link control line **Pb0CC0** only when signal **A** leads signal **B** by 90°.

The **Timer0** function in the PLC is used to generate the trigger pulse **Timer0Out**. **Timer0** itself is triggered by the falling edge of a Boolean combination of **A** and **B** signals, which obtains the correct quadrature phase for the forward direction. Another Boolean combination is used to produce the trigger signal **Pb0CC0** from signal **B** and **Timer0Out**; when the conveyor belt or web moves in the reverse direction, signal **B** masks the trigger pulse **Timer0Out**.

**Timer0** is configured with the following settings to generate a trigger pulse. These values may need to be adjusted depending on the selected camera model and system requirements.

Table 22: PLC Timer Equations

Equation	Description
TimerTriggerSource = TriggerInput	Sets the triggering source for the Timer to be its external trigger input.
TimerTriggerActivation = FallingEdge	Sets the Timer to trigger on the external source's falling edge.
TimerGranularityFactor = Granularity30ns	Sets the interval of the Timer's internal clock tick. For this example, we recommend that the selected factor be at least 8x smaller than the period of the highest frequency expected from the quadrature encoder.
TimerDelayRaw = 1	Sets the delay time before the pulse can start. This is the low period of the pulse after the trigger. This value represents the number of Timer internal clock ticks.
TimerDurationRaw = 6	Sets the duration or high time of the pulse. This value represents the number of internal clock ticks.

The signal routing block in the PLC is configured using the Boolean expressions below. **GpioIn0** is signal **A** and **GpioIn1** is signal **B**. Note that "!" in the Boolean expressions represents *not* or inverted.

Table 23: Signal Routing Block Equations

Equation	Description
$\text{Timer0Trig} = \text{GpioIn0} \ \& \ \text{!GpioIn1}$	Generates the trigger signal for <b>Timer0</b> from signals <b>A</b> and <b>B</b> .
$\text{PbOCC0} = \text{!(Timer0Out} \ \& \ \text{GpioIn0)}$	Masks the trigger for the camera when the conveyor belt or web moves in the reverse direction.

The following table provides recommendations for using quadrature encoders with the industrial models.

Table 24: Quadrature Encoder Recommendations

Encoder output type	Encoder output	GPIO input	Notes
Differential	A	Differential Input0 positive, pin 10 on the 12-pin connector	PLC signal name: GpioIn0
	$\bar{A}$	Differential Input0 negative, pin 8 on the 12-pin connector	
	B	Differential Input1 positive, pin 6 on the 12-pin connector	PLC signal name: GpioIn1
	$\bar{B}$	Differential Input1 negative, pin 3 on the 12-pin connector	
Single-ended	A	Differential Input0 positive, pin 10 on the 12-pin connector	PLC signal name: GpioIn0 Differential Input0 negative, pin 8 is not connected
	B	Differential Input1 negative, pin 6 on the 12-pin connector	PLC signal name: GpioIn0 Differential Input1 negative, pin 3 is not connected



# Chapter 6



## Bulk Interfaces

The CL-U3 has one UART interface for serial communication with a connected Camera Link camera.

The following topics are covered in this chapter:

- [“GenICam Interface for Serial Communication Configuration”](#) on page 44
- [“UART Timing”](#) on page 44

## GenICam Interface for Serial Communication Configuration

The following GenICam features are available for serial communication configuration.

Table 25: GenICam Features Available for Serial Communication

Feature	Description
BulkSelector	Selects Bulk0 for configuration.
BulkBaudRate	Selects a predefined Baud rate or programmable option.
BulkBaudRateFactor	Programs a user-defined Baud rate.
BulkLoopback	Loops back downstream data to upstream direction (loops the data back to the computer).
BulkNumOfStopBits	Selects a stop bit option (either 1 or 2).
BulkParity	Selects a parity option (None, Even, or Odd).
BulkUpstreamFifoWatermark	Controls the number of bytes to accumulate in the Bulk interface upstream FIFO before the CL-U3 delivers them to the host using an event type packet.

## UART Timing

The UART interface supports:

- 8-bit data transfer
- 1 start bit
- Programmable stop bit(s): 1 or 2 stop bits
- Parity: None, Even, or Odd
- Baud rates:
  - Predefined rates: 9600, 14 400, 19 200, 28 800, 38 400, 57 600, 115 200, 230400\*, 460800\*, and 921,600\*
  - Programmable
- Loop back mode from downstream to upstream

\*Available in release 1.3.1 (and later) of the CL-U3 firmware.

Figure 4: UART Timing



A number of preset baud rates can be used. If you require a baud rate that is not covered by the presets, you can specify your own baud rate. To specify your own baud rate:

1. In the **Device Control** dialog box, under **Port Communication**, choose **Programmable** in the **BulkBaudRate** list.
2. In the **BulkBaudRateFactor** field, enter a baud rate between 1 and 511.

The CL-U3 calculates the baud rate using the following equation:  

$$(66.666666 \text{ MHz} * 1000000) / (\text{BulkBaudRateFactor} * 16)$$

\*Available in release 1.3.1 (and later) of the CL-U3.

Table 26: UART Baud Rates

Baud rate, BR (bps)	Notes
9,600	Preset 0 (default)
14,400	Preset 1
19,200	Preset 2
28,800	Preset 3
38,400	Preset 4
57,600	Preset 5
115,200	Preset 6
230,400*	Preset 7
460,800*	Preset 8
921,600*	Preset 9
<b>Maximum BulkBaudRateValue (when BulkBaudRateFactor is set to 1): 4,166,667</b> <b>Minimum BulkBaudRateValue (when BulkBaudRateFactor is set to 511): 8,154</b>	Programmable baud rate

\*Available in release 1.3.1 (and later) of the CL-U3.

The following table provides the A.C. operating characteristics of the UART interface.

Table 27: A.C. Operating Characteristics of the UART Interfaces

Parameter	Symbol	Min	Max	Units	Notes
Data period	t <sub>UART</sub>	0.240	122.64	µs	
Baud rate	BR	8 154	4 166 667	bps	1/t <sub>UART</sub>





# Chapter 7



## Installing the eBUS SDK

This chapter describes how to install the eBUS SDK, and also provides information about installing the required driver.



Before you can configure and control your CL-U3, you must install the eBUS SDK and USB3 Vision driver.

The following topics are covered in this chapter:

- [“Installing the eBUS SDK”](#) on page 48
- [“Installing the eBUS Universal Pro Driver”](#) on page 48

## Installing the eBUS SDK

You can install the Pleora Technologies eBUS SDK on your computer to configure and control your CL-U3.

The eBUS SDK includes:

- Pleora's eBUS Player application, which allows you to control the CL-U3 parameters and view video from a video source connected to the CL-U3.
- An extensive library of sample applications, with source code, to create working applications for device configuration and control, image and data acquisition, and image display and diagnostics.
- Drivers that optimize the performance of your system.

It is possible for you to configure the CL-U3 and USB3 Vision compliant video sources using other GenICam compliant software, however, this guide provides you with the instructions you need to use the Pleora eBUS Player application.

## Installing the eBUS Universal Pro Driver

The eBUS SDK includes a USB3 Vision driver that allows for configuration and control of USB3 Vision devices. The driver must be installed before you can use eBUS Player or any third-party SDK software to configure the CL-U3. If it is not installed, the software will not detect the CL-U3.



The GigE Vision driver, which is available during the installation of the eBUS SDK, is for use with GigE Vision devices, such as the Pleora CL-GigE External Frame Grabber. The driver enhances existing general-purpose drivers shipped with NICs, increases image acquisition throughput and performance, decreases latency and jitter, and minimizes CPU utilization.



The drivers are selected for installation by default during the eBUS SDK installation process. If you choose not to install the drivers (or want to uninstall either driver), you can use the eBUS Driver Installation Tool.

## To use the eBUS Driver Installation Tool

1. Click **Start > All Programs > eBUS SDK > eBUS Driver Installation Tool**.
2. Under **USB3 Vision**, click **Install** or **Uninstall**.

After a moment the driver status changes. If you are installing a driver, the driver is installed across all USB3 Vision devices on your computer.



3. Close the eBUS Driver Installation Tool.  
You may be required to restart your computer.



To see the versions of the installed drivers, click **Help > About**.



# Chapter 8



## Connecting to the CL-U3 and Configuring General Settings Using eBUS Player

After you have set up the physical connections to the CL-U3, you can start eBUS Player to configure image settings, which will help ensure that images are received and displayed properly. You can also configure the buffer options to reduce the likelihood of lost packets.



**BEFORE** you attempt to stream images, you must know the image settings of your Camera Link camera, and then configure the CL-U3 with matching image settings.

The following topics are covered in this chapter:

- “Confirming Image Streaming” on page 52
- “Accessing your Camera Settings through Camera Link Serial Communications” on page 53
- “Configuring CL-U3 Image Settings Using eBUS Player” on page 55
- “Enabling SafePower and PoCL” on page 59
- “Viewing and Testing Streaming Images” on page 61
- “Configuring the Buffers” on page 62
- “Calculating the Required Bandwidth” on page 63
- “Specifying How Images are Acquired” on page 64
- “Recording and Retrieving Images in the Onboard Memory” on page 66
- “Implementing the eBUS SDK” on page 68

## Confirming Image Streaming

After the CL-U3 is physically connected to the computer, use eBUS Player with the test pattern feature enabled to verify that the CL-U3 can stream properly to the computer.

After you have confirmed that eBUS Player is receiving the test pattern from the CL-U3, disable the test pattern so that the CL-U3 can stream images from the camera.



For detailed instructions about how to use eBUS Player, see the *eBUS Player for Windows and Linux User Guide* available on Pleora's Support Center at [supportcenter.pleora.com](http://supportcenter.pleora.com).

### To start eBUS Player and connect to the CL-U3

1. Start eBUS Player from the Windows Start menu.
2. Click **Select/Connect**.
3. In the **Device Selection** dialog box, click the CL-U3 and then click **OK**.
4. Under **How is your camera powered**, your selection will vary depending on the CL-U3 model:
  - **Standard models (CL-U3B and CL-U3M)**. Click **My camera has an external power supply** (these models do not support PoCL).
  - **Industrial models (CL-U3B-IND and CL-U3M-IND)**. Click either option, depending on how you are powering your camera.

When you select **Power is provided by the frame grabber Camera Link cable (PoCL)**, the **ClSafePowerActive** feature\* is set to **True**.

\* The **ClSafePowerActive** feature enables the SafePower protocol on the CL-U3 so it can supply power using PoCL. This protocol also prevents the CL-U3 from attempting to supply power to a camera that does not support PoCL.

5. Click **OK**.

eBUS Player is now connected to the CL-U3.

### To turn the test pattern on or off

1. Start eBUS Player and connect to the CL-U3.  
For more information, see “[To start eBUS Player and connect to the CL-U3](#)” on page 52.
2. Under **Parameters and Controls**, click **Device Control**.
3. Under **ImageFormatControl**, click a test pattern option in the **TestPattern** list.
4. Close the **Device Control** dialog box.

5. When the test pattern is enabled and you click **Play**, you will see an image similar to this (the pattern and colors may vary, depending on the image settings).

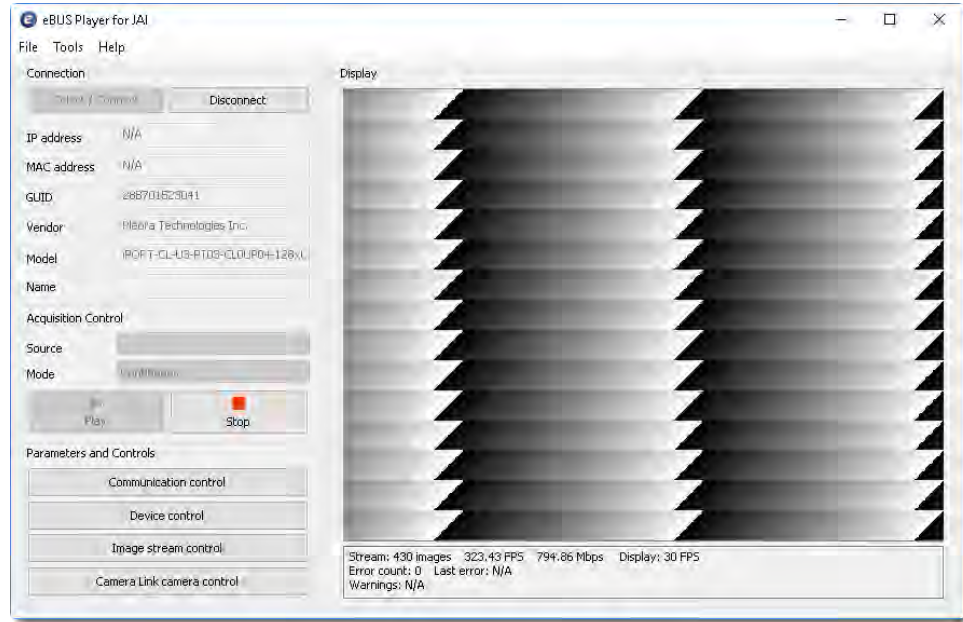

## Accessing your Camera Settings through Camera Link Serial Communications

You can use eBUS Player to send serial commands between the CL-U3 and the Camera Link camera. For a list of commands that can be sent to the camera, consult the camera's technical documentation.



This section explained how to send serial commands between the CL-U3 and the camera. Alternatively, you can establish a serial bridge or camera bridge to communicate with your camera using serial communication.

The following options are available:

- GenCP communication, for cameras that are GenCP compliant.
- Serial port (COM port) communication, which you will use if your camera manufacturer has provided a software application that assumes that you use a serial port on your computer to send serial commands to the camera.
- Camera Link DLL, which you will use if your camera manufacturer has provided a software application that uses a Camera Link DLL to send serial commands to the camera.
- GenICam CLProtocol library, which you will use if you have a CLProtocol DLL (provided by the camera manufacturer).

For information about using these serial communication methods, see the knowledge base article titled *Introduction: Establishing a Serial Bridge* on the Pleora Support Center at [supportcenter.pleora.com](http://supportcenter.pleora.com).

## To send serial commands to your camera using eBUS Player

1. Start eBUS Player and connect to the CL-U3.
2. On the **Tools** menu, click **Device Serial Communication**.

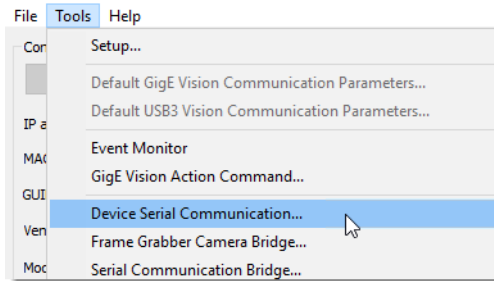

3. In the **Port Selection** list, ensure the bulk port is selected.
4. In the **Speed** list, select the baud rate that matches your camera.

**Tip:** If you need to set the parity and stop bits, click **Device control** on the main page of eBUS Player. In the **Visibility** list, click **Guru**. Under **IP Engine > PortCommunication**, set the values for these options.

5. Under **Send as**, select the data transmission sequence format by clicking either **ASCII** (text only) or **Hexadecimal**.

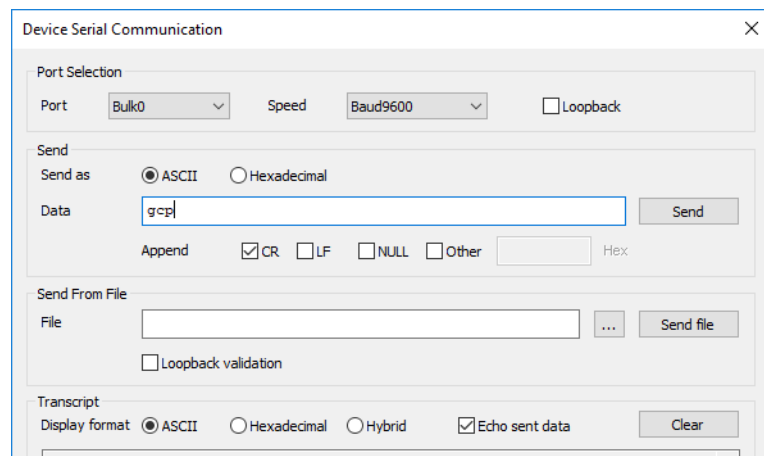

6. Type the data string in the **Data** box.  
For hexadecimal, enter a pair of hexadecimal digits for each byte, separated by spaces. For example, 01 23 45 67 89 AB CD EF.
7. Select one of the trailer options beside **Append**.  
Trailer options are not mutually exclusive; they append in the order shown.  
Select **Other** for ASCII and hexadecimal sequences in custom trailers for devices that do not use the trailer options in the order shown, for example, CR and LF.
8. Click **Send** to transmit the data sequence.
9. Wait for the device to reply.
10. Close the **Device Serial Communication** dialog box.



## Configuring CL-U3 Image Settings Using eBUS Player

After you have configured your Camera Link Camera with optimal image settings, you must configure matching image settings on the CL-U3.



The changes that you make to your CL-U3 are temporary and will not persist across power cycles. To understand more about how to save your settings, see [“Saving eBUS Player and CL-U3 Settings”](#) on page 69.

### Take note of the camera’s image settings

Take note of the camera’s image settings. You can find this information by consulting the camera’s technical documentation or by using the camera configuration software that accompanies your camera.

- Scan type (area scan or line scan)
- Number of taps (sometimes referred to as tap geometry or sensor digitization taps)
- Image width
- Image height
- Pixel bit depth (8, 10, 12 bits, or more)
- Pixel format

These settings may not be available in the software; you may need to use the camera’s technical documentation to find this information. If you cannot find the pixel format, you should start by configuring the CL-U3 to use a Mono (monochrome) setting.

- Power source (from a power supply or PoCL)

To ensure the CL-U3 is streaming images properly, you must configure the CL-U3’s image settings to match those previously configured on the camera.

## Supported Device Tap Geometries for the CL-U3

The following table lists the supported device tap geometries for the CL-U3. Please note that the CL-U3 does not support tap reconstruction for the supported tap geometries (that is, the taps are received in order from the camera).

Table 28: Supported Camera Link Tap Geometries

Tap geometry	Number of taps	Scan type
<b>CL-U3B, CL-U3B-IND, CL-U3M, and CL-U3M-IND</b>		
Geometry_1X_1Y	1	Areascan
Geometry_1X2_1Y	2	Areascan
Geometry_1X	1	Linescan
Geometry_1X2	2	Linescan
<b>CL-U3M and CL-U3M-IND</b>		
Geometry_1X4_1Y	4	Areascan
Geometry_1X4	4	Linescan



If your camera outputs a tap geometry that is not listed in Table 28, you may need to perform tap reconstruction using your software application. For more information about tap geometry, refer to the *GenICam Standard Features Naming Convention* (Version 2.0 or later), available from the European Machine Vision Association at <http://www.emva.org>.

## To configure image settings on the CL-U3

1. Start eBUS Player and connect to the CL-U3.  
For more information, see [“To start eBUS Player and connect to the CL-U3”](#) on page 52.
2. In the **Visibility** list, click **Expert**.
3. Under **DeviceControl**, select a sensor scan type (areascan or linescan) in the **DeviceScanType** list.

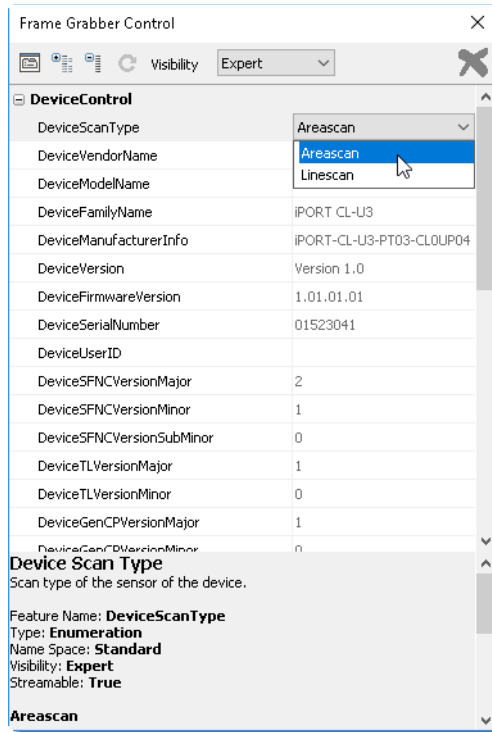

4. Under **ImageFormatControl**, select the number of taps in the **SensorDigitizationTaps** list.

**Note:** In release 1.0.1, turning on the **TestPattern** substantially limits the number of available pixel formats. In 1.3.1 and later, there is no impact to the number of available pixel formats.

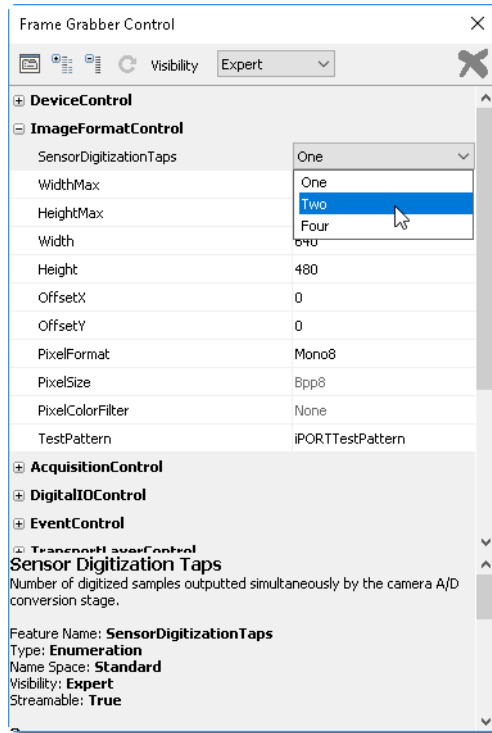

**DeviceScanType, SensorDigitizationTaps, PixelFormat, and TestPattern** are interrelated. When you change any of these values, the CL-U3 may automatically adjust the other values to ensure the configuration is valid.

5. Under **ImageFormatControl**, enter the image width and height, and select a pixel format from the **PixelFormat** list.
6. Close the **Device Control** dialog box.
7. Click **Play** to see the changes.

## Enabling SafePower and PoCL

The industrial models can supply power to one Camera Link Base or one Camera Link Medium camera (depending on your model), using PoCL. When you use PoCL, power is supplied over one standard Camera Link cable (for Camera Link Base models) or two standard Camera Link cables (for Camera Link Medium models), as outlined in the *Camera Link Standard*.

To allow the industrial models to supply power to Camera Link cameras using PoCL, enable the **ClSafePowerActive** feature. When this feature is enabled, PoCL is active and the SafePower protocol is used, which prevents the CL-U3 from attempting to supply power to a non-PoCL cable or camera.

### To enable SafePower and PoCL and to view the PoCL status (industrial models only)

1. Start eBUS Player and connect to the CL-U3.  
For more information, see [“To start eBUS Player and connect to the CL-U3”](#) on page 52.
2. In the **Visibility** list, click **Expert** or **Guru**.
3. Under **CameraLinkInterfaceControl**, select a connector in the **ClConnectorSelector** list. See the table below for connector selection information.
4. In the **ClSafePowerActive** list, click **True** to enable SafePower and PoCL.

Table 29: Connector Selection for Enabling Camera Link SafePower

CL-U3 model	ClConnectorSelector list item	CL-U3 connector
CL-U3B-IND	Connector1	CL1
CL-U3M-IND	Connector1	CL1
	Connector2	CL2

5. Review the status that appears under **CISafePowerStatus**. The following flowchart explains the status changes. Please note that each connector performs this process independently.

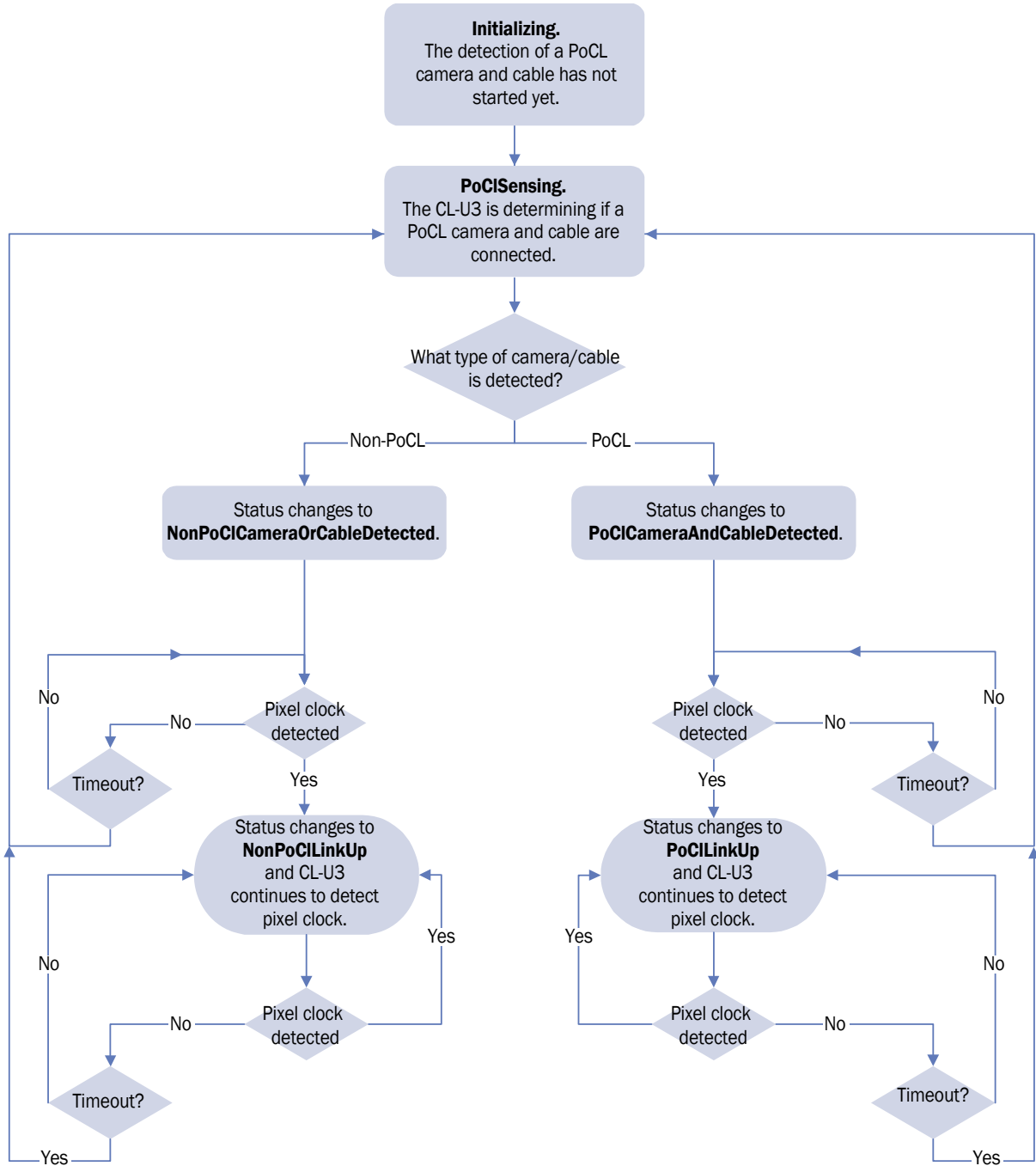

## Viewing and Testing Streaming Images

You can view and test your image settings using eBUS Player.



To view images from the camera, the test pattern must be disabled. For more information, see [“To turn the test pattern on or off”](#) on page 52.

### To view streaming images in eBUS Player

1. Start eBUS Player and connect to the CL-U3.

For more information, see [“To start eBUS Player and connect to the CL-U3”](#) on page 52.

2. Under **Acquisition Control**, select the acquisition mode you want to use to acquire images. By default, images are streamed in **Continuous** mode (the CL-U3 sends a stream of continuous images instead of a single image).

For other acquisition modes, see [“Specifying How Images are Acquired”](#) on page 64.

3. Click **Play**.

The images appear in the **Display** section of eBUS Player.

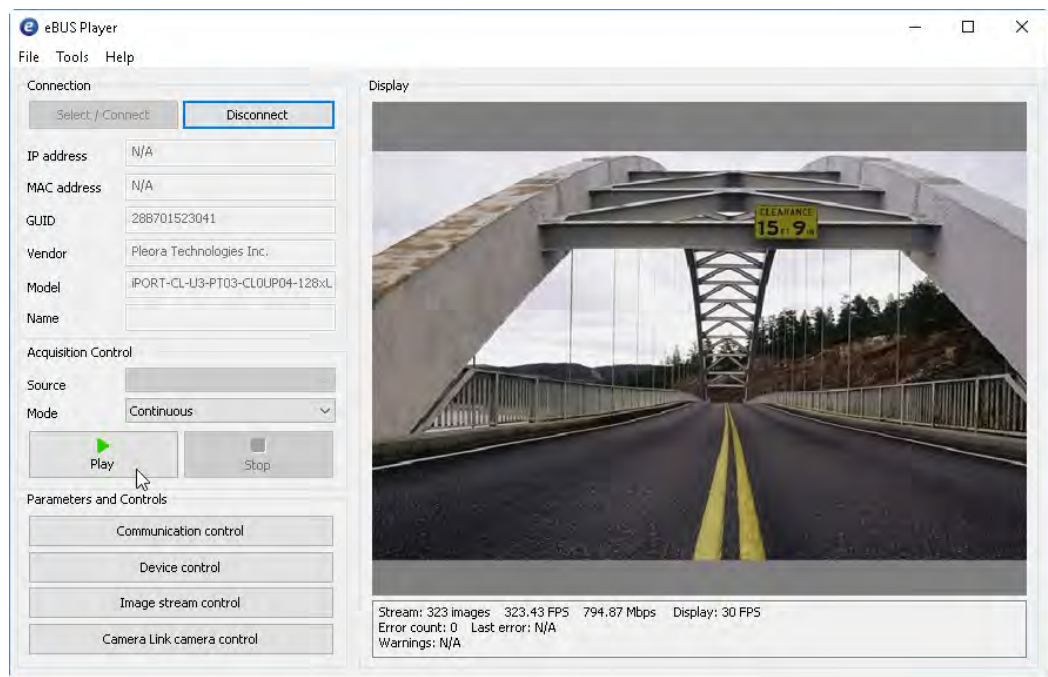

Example image. When the test pattern is enabled for the CL-U3, a stream of moving lines will appear (often black, gray, and white) instead of video from your camera.



If images or the test pattern do not stream, see the tips provided in [“System Troubleshooting”](#) on page 75.

## Configuring the Buffers

You can increase the buffer count using eBUS Player to make streaming more robust. A high number of buffers are needed in high frame rate applications, while a small number of buffers are needed for lower frame rates. Latency increases as the number of buffers increases.

### To configure the buffers

1. Start eBUS Player.
2. Click **Tools > Buffer Options**.
3. Click the buffer option that suits your requirements.
4. Click **OK**.

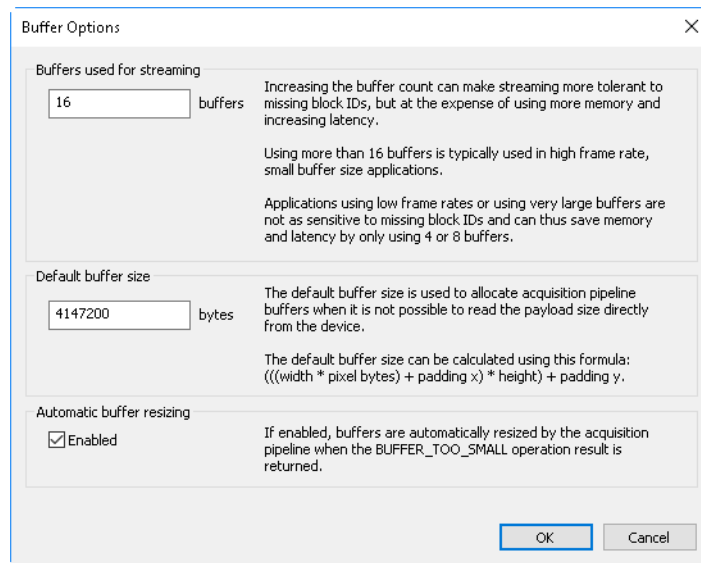

Default size for streaming is 16 buffers.



## Calculating the Required Bandwidth

When using the CL-U3 and connected Camera Link camera, you may observe high data rates.

To calculate the approximate bandwidth that is required, use the following formula. Keep in mind that this calculation results in an approximate value, and does not take into account USB3 Vision overhead. Note that each image is broken up into many packets, which should be considered when determining overhead.



**PayloadSize** is automatically calculated by the CL-U3, based on the selected image settings, which include **Width, Height, OffsetX, OffsetY, PixelSize**, and any padding that has to be added to the image payload. To see the **PayloadSize**, open eBUS Player, connect to the CL-U3, and then click **Device control**. **PayloadSize** appears in the **TransportLayerControl** category.

For example, for a CL-U3 configured with 1280 x 720, a 16-bit pixel format, and a **PayloadSize** of 1.84 MB at 60 frames per second, the equation would look like this:

$$1.84 \text{ MB} \times 8 \times 60 \text{ Hz} = 883.2 \text{ Mbps}$$

## Specifying How Images are Acquired

**Continuous**, **SingleFrame**, and **MultiFrame** modes are usually standard for external frame grabbers. Acquisition starts when the **Play** button is pressed (the **AcquisitionStart** command is executed).



The acquisition modes supported by the CL-U3 are enumerated by the GenApi **AcquisitionMode** feature.

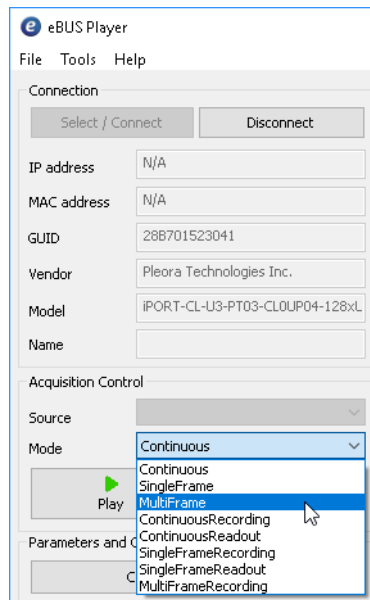

**eBUS Player Main Page**

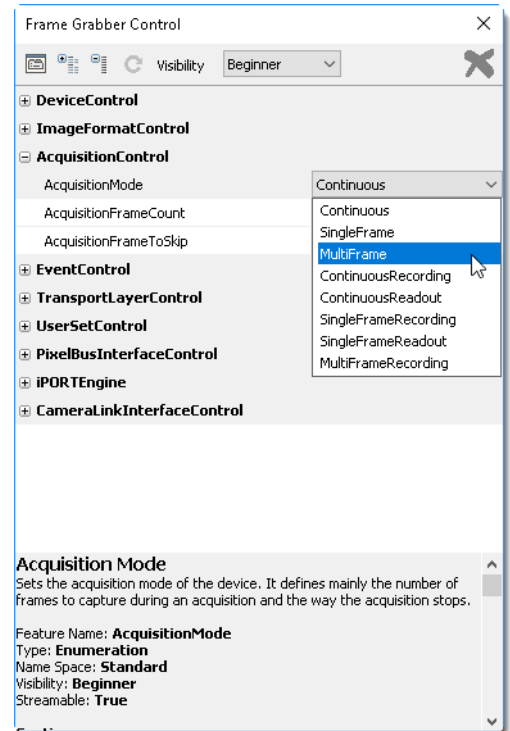

**Device Control Dialog Box**

## Continuous Mode

This mode allows you to acquire images continuously and is the default mode for most external frame grabbers.

## Multiframe Mode

This mode allows you to acquire a fixed number of images. To configure the number of images, set the CL-U3's **AcquisitionControl > AcquisitionFrameCount** feature.

You can set the **AcquisitionControl > AcquisitionFrameCount** feature in the **Device Control** dialog box, as shown in the following image.

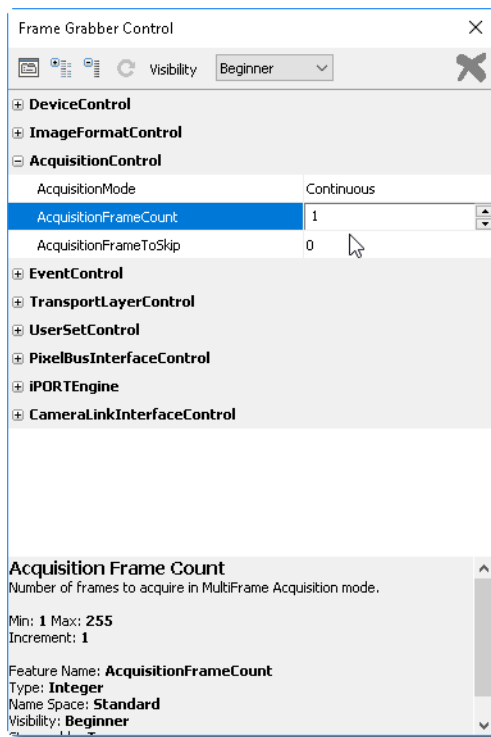

## SingleFrame Mode

This mode allows you to acquire a single image.

## Recording and Retrieving Images in the Onboard Memory

The **recording** acquisition modes allow you to capture images from a camera and store them in the CL-U3's onboard memory.

The **readout** acquisition modes allow images to be acquired from the CL-U3's memory at a slower rate, ensuring images are not lost.

These modes are helpful when you are working with a camera that transmits images at a rate that exceeds the connection between the CL-U3 and the computer, resulting in dropped images. For example, a Base Configuration Camera Link camera transmits images at up to 2.04 Gbps (2 taps of 12 bits) but the connection to the computer might be only 1 Gbps. By using the recording and readout modes in this example, you can capture and stream images from the camera without losing any images (as long as there is space in the onboard memory).



While a Medium configuration Camera Link camera can transmit images at up to 4.08 Gbps, it is limited by the USB 3.0 connection, which is approximately 3 Gbps.

The recording acquisition modes support back-to-back recording, which allows you to click the **Stop** and **Play** buttons multiple consecutive times without clearing the onboard memory.

Acquisition starts when the **Play** button is pressed (the **AcquisitionStart** command is executed) when one of the recording modes is selected.

Images can be stored in the CL-U3's onboard memory as long as there is space or until there are 512 images in memory. For information about calculating how many images you can store, see [“Calculating How Many Images Can be Stored in Onboard Memory”](#) on page 68.



If the USB cable is disconnected, or if the computer is restarted, all captured images will be lost.

### ContinuousRecording Mode

With this mode, images are acquired continuously and are stored in the CL-U3's onboard memory until the memory is full (or 512 images are stored in onboard memory). When this limit is reached, the CL-U3 stops acquiring new images from the camera.

We recommend that you observe **AcquisitionControl > BlockBufferCount** (**Expert** or **Guru** visibility level is required). When the value for this feature stops increasing, the memory is full. For information about the actions that clear the images from onboard memory, see [“Understanding When Images are Removed from the Onboard Memory”](#) on page 68.



To determine how many images can be stored in memory, see [“Calculating How Many Images Can be Stored in Onboard Memory”](#) on page 68.

## ContinuousReadout Mode

With this mode, images are continuously read (and removed) from the CL-U3's onboard memory. The readout begins at the first image in memory. To see the number of images stored in onboard memory, see **AcquisitionControl > BlockBufferCount** in the **Device Control** dialog box (**Expert** or **Guru** visibility level is required).

Readout continues until the **Stop** button is pressed (**AcquisitionStop** command is executed) or until the last image has been sent by the device (**BlockBufferCount** will be 0).

## MultiFrameRecording Mode

With this mode, a fixed number of images are stored in the CL-U3's onboard memory. To configure the number of images, set the **AcquisitionControl > AcquisitionFrameCount** feature in the **Device Control** dialog box. Images can be read out from memory using **ContinuousReadout** mode.



A maximum of 512 images can be acquired at one time in MultiFrameRecording mode.



To determine how many images can be stored in memory, see [“Calculating How Many Images Can be Stored in Onboard Memory”](#) on page 68.

If **AcquisitionControl > AcquisitionFrameCount** is set to a value that exceeds the amount of available memory, the CL-U3 stops acquiring new images when the onboard memory is full (or 512 images are stored in onboard memory).

**BlockBufferCount** shows the number of images currently in memory. In MultiFrameRecording mode, this number is cumulative: If the memory is empty and you acquire an image, **BlockBufferCount** will match the **AcquisitionFrameCount**. If you stop and restart recording, **BlockBufferCount** will increment (to a maximum of 512 images, depending on the image size) and will no longer match the **AcquisitionFrameCount**.

For information about the actions that clear the images from onboard memory, see [“ContinuousReadout Mode”](#) on page 67.

## SingleFrameRecording Mode

With this mode, a single image is saved in the CL-U3's onboard memory after each **AcquisitionStart** command.

For information about the actions that clear the images from onboard memory, see [“Understanding When Images are Removed from the Onboard Memory”](#) on page 68.

## SingleFrameReadout Mode

With this mode, a single image is acquired from the CL-U3's onboard memory.

## Understanding When Images are Removed from the Onboard Memory

The following actions remove the images from the CL-U3's onboard memory:

- Streaming images from the onboard memory using one of the readout acquisition modes (**ContinuousReadout** or **SingleFrameReadout**).
- Power cycling the CL-U3, which clears all images from the onboard memory.
- Making any of the following **AcquisitionMode** changes and then clicking the **Play** button (**AcquisitionStart** command):

Table 30: Changes that Clear Images from the Onboard Memory

First you acquire images with...	And then you change the Acquisition mode to...
ContinuousRecording, MultiFrameRecording, or SingleFrameRecording	Continuous, MultiFrame, or SingleFrame
SingleFrameReadout or ContinuousReadout	SingleFrame, MultiFrame, or Continuous
SingleFrameReadout or ContinuousReadout	ContinuousRecording, MultiFrameRecording, or SingleFrameRecording

## Calculating How Many Images Can be Stored in Onboard Memory

First, take note of the **PayloadSize**, which appears under **TransportLayerControl** in the **Device Control** dialog box. Expert or Guru visibility level is required to access this feature.

The **PayloadSize** is automatically calculated by the CL-U3 based on the selected image settings, which include Width, Height, OffsetX, OffsetY, PixelSize, any chunk data, as well as any padding that has to be added to the image payload.

For example, for a CL-U3 configured to use Mono10p with images that are 1920 x 1080, the **PayloadSize** is equal to 2 592 000 bytes per image or 2.472 MB (2 592 000 / 1 048 576).

You can use the following equation to determine the number of images that can be saved in onboard memory:

**Available onboard memory MB / PayloadSize MB = Number of images that can be saved**

Using our example, the equation is:

**120 MB / 2.472 MB = 48 images**

## Implementing the eBUS SDK

You can create your own image acquisition software for the CL-U3. Consult the following guides for information about creating custom image acquisition software:

- *eBUS SDK API Quick Start Guides*, available for C++, .NET, Linux, and macOS, which are available on the Pleora Support Center at [supportcenter.pleora.com](http://supportcenter.pleora.com).
- *eBUS SDK API Help Files*, which are installed on your computer during the installation of the eBUS SDK. You can access this documentation from the Windows Start menu under **eBUS SDK**.

# Chapter 9



## Saving eBUS Player and CL-U3 Settings

This chapter describes the various ways to save your eBUS Player and CL-U3 settings.



The changes that you make to your CL-U3 are temporary and **WILL NOT PERSIST ACROSS POWER CYCLES** unless you save the changes to the flash memory of the CL-U3 or to a .pvcfg file on your computer.

The following topics are covered in this chapter:

- “Choosing the Best Method for Saving eBUS Player and CL-U3 Settings” on page 70
- “Using File > Save” on page 72
- “Using Tools > Save Preferences” on page 72
- “Using User Sets: Saving Settings to the CL-U3’s Flash Memory” on page 73
- “Ensuring Configuration Settings are not Overwritten” on page 74
- “Saving the CL-U3 XML File to your Computer” on page 74

## Choosing the Best Method for Saving eBUS Player and CL-U3 Settings

eBUS Player offers several ways to save your eBUS Player and CL-U3 settings. Each method saves different settings, as outlined in the following table.

Table 31: eBUS Player and CL-U3 Settings Saving Options

	Format and location of saved settings:		
	Saves to a .pvcfg file on your computer	Saves to your computer's user profile	Saves to the CL-U3 flash memory
	eBUS Player procedure for saving:		
	File > Save	Tools > Save preferences	Device Control > Usersets
	Settings saved:		
Default USB 3.0 host-side communication parameters. These parameters are set using the <b>Default USB3 Vision Communication Parameters</b> dialog box, accessed from the <b>Tools</b> menu in eBUS Player.	Yes	Yes	No
USB 3.0 host-side communication parameters. These parameters are set using the <b>Communication Control</b> dialog box (click the <b>Communication control</b> button on the main page of eBUS Player).	Yes	No	No
CL-U3 parameters. These parameters are set using the <b>Device Control</b> dialog box (click the <b>Device control</b> button on the main page of eBUS Player).	Yes	No	Yes
Image stream parameters. These parameters are set using the <b>Image Stream Control</b> dialog box (click the <b>Image stream control</b> button on the main page of eBUS Player).	Yes	No	No



Table 31: eBUS Player and CL-U3 Settings Saving Options (Continued)

	Format and location of saved settings:		
	Saves to a .pvcfg file on your computer	Saves to your computer's user profile	Saves to the CL-U3 flash memory
	eBUS Player procedure for saving:		
	File > Save	Tools > Save preferences	Device Control > Usersets
	Settings saved:		
<p><b>1.</b> eBUS Player settings accessed from the <b>Tools</b> menu:</p> <ul style="list-style-type: none"> <li>• Setup: eBUS Player role and stream destination</li> <li>• Image filtering</li> <li>• Image saving</li> <li>• Event monitor</li> <li>• Buffer options</li> <li>• Display options</li> </ul> <p><b>2.</b> GenlCam browser settings configured using the <b>Device Control</b> dialog box: Parameter visibility level, browser options, expanded or collapsed feature lists.</p>	Yes	Yes	No
<p>Serial communication bridge settings.</p> <p>These parameters are set using the <b>Serial Communications Bridge</b> dialog box, accessed from the <b>Tools</b> menu.</p>	Yes	No	No
<p>Camera bridge configuration settings.</p>	Yes	Yes	No
<p>Identification (GUID) of devices to which you are connected.</p>	Yes	No	No
<p>CL-U3 serial communication settings.</p> <p>These parameters are set using the <b>Device Serial Communication</b> dialog box accessed from the <b>Tools</b> menu.</p>	No	No	No



For more information about the settings and parameters shown in the table above, see the *eBUS Player For Windows and Linux User Guide*.

## Using File > Save

When you select **Save As** on the eBUS Player **File** menu, the changes you have made to the eBUS Player application settings, along with most of the settings configured on the CL-U3 to which eBUS Player is connected, are saved to a .pvcfg file on your computer. When you are next connected to the CL-U3 using eBUS Player, you can apply the saved .pvcfg file to restore all of your previously configured settings.

The settings saved to the .pvcfg file include the GUID of the connected CL-U3. This enables you to connect to the device automatically and restore the CL-U3 and eBUS Player application settings. For more information about the eBUS Player settings saved using this method, see “[eBUS Player and CL-U3 Settings Saving Options](#)” on page 70.

### To save CL-U3 settings to a .pvcfg file on your computer

1. After you have changed settings on the CL-U3 using eBUS Player, click **File > Save As**.
2. Choose a file name and location on your computer to save the .pvcfg file.
3. Click **Save**.

### To apply a saved .pvcfg file to the CL-U3

1. Connect to the CL-U3 using eBUS Player.
2. Click **File > Open**.
3. Navigate to the saved .pvcfg file and click **Open**.



You can apply the settings in the saved .pvcfg file to a CL-U3 with a different GUID.

## Using Tools > Save Preferences

When you select **Save Preferences** on the eBUS Player **Tools** menu, specific eBUS Player application settings along with **Communication control** options, such as a specific heartbeat interval and answer timeout value, are saved to your Windows/Linux/macOS operating system user profile. When you next open eBUS Player, your preferences are the same as when you closed the application. For more information about the eBUS Player settings saved using this method, see “[eBUS Player and CL-U3 Settings Saving Options](#)” on page 70.



The **Device control** settings and the **Image stream** control settings are not saved when you click **Save Preferences**.

### To save eBUS Player preferences

- Click **Tools > Save Preferences**.

The eBUS Player preferences, including the **Communication control** options such as a specific heartbeat interval and answer timeout value, are saved.

### To restore default eBUS Player settings

- Click **Tools > Restore Default Preferences**.

Settings are restored to the values set on the CL-U3 before it was first used.

## Using User Sets: Saving Settings to the CL-U3's Flash Memory

When you use the **UserSetSave** feature available in the **UserSetControl** section of the eBUS Player **Device Control** dialog box, you are saving configuration changes to the flash memory of the CL-U3. These settings persist across power cycles. A User Set can be configured to be the default settings for the CL-U3 so that each time you start the CL-U3 it starts with these settings applied, or you can start the CL-U3 and then apply User Set configurations.

Most Pleora external frame grabbers support two User Sets: **UserSet1**, which consists of the user-configured settings, and **Default**, which consists of the pre-configured settings, to which you can always revert. Settings identified as **Default** in the **Device Control** dialog box cannot be changed.



Not all CL-U3 configuration changes can be saved to a User Set. Features in the **Device Control** dialog box that can be saved to the CL-U3's flash memory have **Streamable: True** in the Help section at the bottom of the **Device Control** dialog box.

The following table describes the options available in **UserSetControl**.

Table 32: Saving Configuration Settings to the CL-U3

Setting	Description
UserSetSelector	Selects the User Set to load or save.
UserSetLoad	Loads the User Set (specified by <b>UserSetSelector</b> ) to the CL-U3 and makes it active.
UserSetSave	Saves configuration data to the User Set specified by <b>UserSetSelector</b> , which is part of the non-volatile memory of the CL-U3.
UserSetDefaultSelector	Specifies the User Set to load and make active when the CL-U3 is reset or power-cycled.
UserSetLoadLastUserSet	Shows the last User Set executed by the CL-U3 from a <b>UserSetLoad</b> command, or as a result of a reset (or power cycle) of the CL-U3.
UserSetLoadStatus	Indicates the success or failure of the last User Set applied. The User Set can be applied through a power cycle or through user selection.

### To save a configuration change to UserSet1

1. In the **Device Control** dialog box, make the required configuration changes.
2. Under **UserSetControl**, change the **UserSetSelector** setting to **UserSet1**.
3. Click **UserSetSave**.

### To load the default configuration settings (one-time)

1. In the **UserSetControl** section of the **Device Control** dialog box, select **Default** in the **UserSetSelector** box.
2. Click the **UserSetLoad** setting and then click the **UserSetLoad** button that appears to the right. The default settings are applied to the CL-U3.

### To specify the persistent settings that are loaded every time the CL-U3 is reset

- In the **UserSetControl** section of the **Device Control** dialog box, select a User Set in the **UserSetDefaultSelector** box and then close the **Device Control** dialog box. The next time the CL-U3 is reset or power cycled, the User Set that you selected is loaded.

## Ensuring Configuration Settings are not Overwritten

When you choose a method to save eBUS Player and CL-U3 settings, you could overwrite previously configured settings. You should consider the following when saving settings.

- Each newly applied .pvcfg file overwrites all settings configured by a previously applied .pvcfg file.
- Each newly applied .pvcfg file overwrites the settings from a previously applied User Set.
- When you apply CL-U3 settings from a User Set, device settings configured by a previously applied .pvcfg are overwritten.

## Saving the CL-U3 XML File to your Computer

You can save the CL-U3 XML file to your computer.



This allows you to view the CL-U3's GenICam XML file; it does not save your eBUS Player or camera settings.

### To save your camera's XML file

1. Click **Tools > Save GenICam XML**.
2. Navigate to the location in which you want to save the XML file. Click **Save**.

# Chapter 10



## System Troubleshooting

This chapter provides you with troubleshooting tips and recommended solutions for issues that can occur during configuration, setup, and operation of the CL-U3. It also shows you how to switch between the backup and main firmware loads.



Not all scenarios and solutions are listed here. You can refer to the Pleora Technologies Support Center at [supportcenter.pleora.com](https://supportcenter.pleora.com) for additional support and assistance. Details for creating a customer account are available on the Pleora Technologies Support Center.



Refer to the product release notes that are available on the Pleora Technologies Support Center for known issues and other product features.

## Troubleshooting Tips

The scenarios and known issues listed in this chapter are those that you might encounter during the setup and operation of your CL-U3. Not all possible scenarios and errors are presented. The symptoms, possible causes, and resolutions depend upon your particular setup and operation.



If you perform the resolution for your issue and the issue is not corrected, we recommend you review the other resolutions listed in this table. Some symptoms may be interrelated.

Table 33: Troubleshooting Tips

Symptom	Possible cause	Resolution
<p>When selecting the CL-U3 for connection, the <b>Speed</b> (in the <b>Device Selection</b> dialog box in eBUS Player) says <b>High</b> instead of <b>Super</b>, and a warning icon appears.</p> 	<p>The CL-U3 is connected to a USB 2.0 port on your computer, not a USB 3.0 port.</p> <p>The USB 3.0 port may have experienced a power surge.</p>	<p>Connect the CL-U3 to a USB 3.0 port on your computer.</p> <p>Troubleshoot the USB 3.0 port in your computer by:</p> <ul style="list-style-type: none"> <li>Connecting the CL-U3 to another USB 3.0 port on your computer.</li> <li>Disconnecting the CL-U3 from the computer and rebooting the computer.</li> </ul>
<p>When you connect the CL-U3 to a USB port on your computer, a Windows warning appears, indicating that the driver could not be installed.</p>	<p>The Pleora USB3 Vision driver is not installed on your computer.</p>	<p>Install the Pleora USB3 Vision driver on your computer using the eBUS Driver Installation Tool (<b>Start &gt; All Programs &gt; eBUS SDK &gt; eBUS Driver Installation Tool</b>).</p>
<p>When selecting the CL-U3 for connection, the <b>License</b> field (in the <b>Device Selection</b> dialog box in eBUS Player) says <b>Unavailable</b>. <b>Resolve other errors</b>. And the <b>Pleora Driver Installed</b> field says <b>Unknown</b>.</p> 	<p>The Pleora USB3 Vision driver is not installed on your computer.</p>	<p>Install the Pleora USB3 Vision driver on your computer using the eBUS Driver Installation Tool.</p>

Table 33: Troubleshooting Tips (Continued)



Symptom	Possible cause	Resolution
<p>The <b>License</b> field (in the <b>Device Selection</b> dialog box in eBUS Player) says <b>Invalid</b>.</p> <p></p> <p></p> <p>The CL-U3 appears in the <b>Device Selection</b> dialog box in eBUS Player but you cannot connect to it.</p>	<p>The Pleora USB3 Vision driver is not installed, or not installed correctly on your computer.</p> <p>If you have a third-party USB3 Vision driver on your computer, that driver may be interfering with the Pleora USB3 Vision driver's ability to recognize the CL-U3.</p> <p>For the industrial models, the CL-U3 may have been connected to the USB port before it was connected to the external power supply.</p> <p>For the industrial models, external power is not being supplied to the CL-U3.</p> <p>The USB host controller is shared, resulting in an inadequate power supply.</p>	<p>Install the Pleora USB3 Vision driver on your computer using the eBUS Driver Installation Tool.</p> <p>Uninstall the third-party driver and install the Pleora USB3 Vision driver on your computer using the eBUS Driver Installation Tool.</p> <p>Disconnect the CL-U3 from the USB port. Connect it to an external power supply and then reconnect it to the USB port.</p> <p>Disconnect the CL-U3 from the USB port. Connect it to an external power supply and then reconnect it to the USB port.</p> <p>Disconnect devices from your USB hub that are drawing power from the USB hub.</p>
<p>The <b>License</b> field (in the <b>Device Selection</b> dialog box in eBUS Player) says <b>Unlicensed. Watermark, limited use</b>.</p> <p></p> <p>A Pleora watermark appears on transmitted and received images.</p>	<p>Your camera does not use Pleora's technology for device control and to transmit and receive images.</p>	<p>Purchase a Pleora eBUS SDK USB3 Vision Receiver license to license the camera and remove the watermark. For more information, visit <a href="http://www.pleora.com/products/ebus-sdk">www.pleora.com/products/ebus-sdk</a>.</p>
<p>Image errors appear as soon as you click <b>Play</b> and images do not stream.</p>	<p>The CL-U3 settings may not match the configuration of the image data that is being received from the camera.</p>	<p>Ensure the following CL-U3 settings match the configuration of the image data from the camera:</p> <ul style="list-style-type: none"> <li>• DeviceScanType</li> <li>• SensorDigitizationTaps</li> <li>• PixelFormat</li> <li>• Width</li> <li>• Height</li> </ul>
<p>Images do not appear and the image count (located beside <b>Stream</b> at the bottom of eBUS Player) does not increase when you click <b>Play</b>.</p>	<p>The test pattern is off.</p>	<p>Turn the test pattern on.</p>
	<p>No video source is available.</p>	<p>Connect a video source and ensure that <b>PixelBusInterfaceControl</b> &gt; <b>PixelBusClockPresent</b> is <b>True</b>.</p>

Table 33: Troubleshooting Tips (Continued)

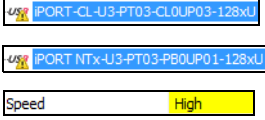
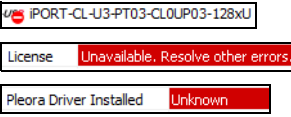
Symptom	Possible cause	Resolution
Dropped images, dropped connection, or failure to connect to the CL-U3.	The power supply from the USB port may be inadequate  For the standard models, the power supply from the USB port may be inadequate.	Ensure 900 mA is available from the USB port. For more information, see <a href="#">“Powering the CL-U3”</a> on page 26.
After resetting the CL-U3 using the <b>DeviceReset</b> feature in eBUS Player and then trying to reconnect to the CL-U3, the error message “ABORTED. Error reading manifest table address.” appears and you cannot connect to the CL-U3.	You tried to connect to the CL-U3 too soon after using the <b>DeviceReset</b> feature.	Wait at least ten seconds before you attempt to reconnect to the CL-U3 after using the <b>DeviceReset</b> feature.

## Changing to the Backup Firmware Load

In the event that the main firmware load fails to start, the CL-U3 will start up using the backup firmware load when it is restarted or power cycled.

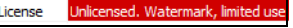
In the rare event that the backup load is not used automatically (as indicated by the fact that eBUS Player will not be able to detect the CL-U3), you can use the slide switch to change to the backup load.

After the CL-U3 starts up using the backup load, you can apply a firmware update to the CL-U3 to recover the main load. For more information see the *Updating Pleora Firmware* knowledge base article on the Pleora Support Center ([supportcenter.pleora.com](http://supportcenter.pleora.com)).

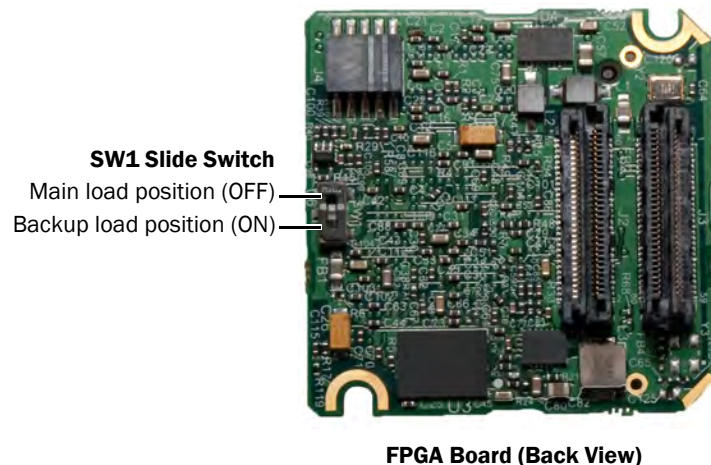

FPGA Board (Back View)



# Chapter 11



## Reference: Mechanical Drawings and Material List

This chapter provides mechanical drawings and also provides a list of connectors with corresponding manufacturer details.



Three-dimensional (3-D) mechanical models are available at the Pleora Technologies Support Center.

The following topics are covered in this chapter:

- [“Mechanical Drawings”](#) on page 80
- [“Enclosed Models”](#) on page 80
- [“CL-U3B-IND OEM Board Set”](#) on page 82
- [“CL-U3M-IND OEM Board Set”](#) on page 85
- [“GPIO Board Assembly”](#) on page 88
- [“Material List”](#) on page 90
- [“Using USB3 Vision Locking Cables with the Inverted Micro-B USB 3.0 Connector”](#) on page 90

## Mechanical Drawings

The mechanical drawings in this section provide the CL-U3's dimensions, features, and attributes. All dimensions are in millimeters. Connectors are dimensioned to the center.



The drawings in this section include all connectors that could be present on any CL-U3. Because there are different CL-U3 models, your device may not have all of the connectors shown in this chapter.

### Enclosed Models

Figure 5: Enclosed Model — Camera Link Camera Side

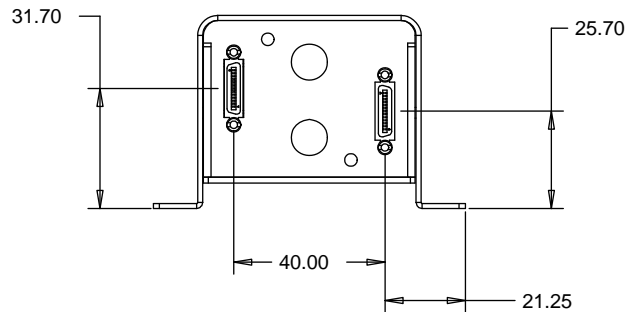

Figure 6: Enclosed Model — Side View

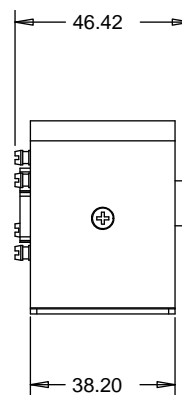

Figure 7: Enclosed Model – Top View

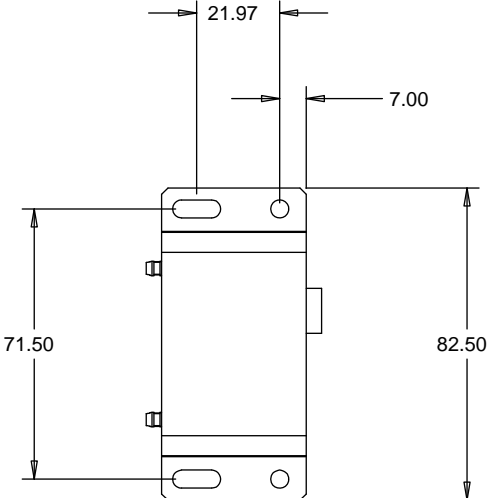
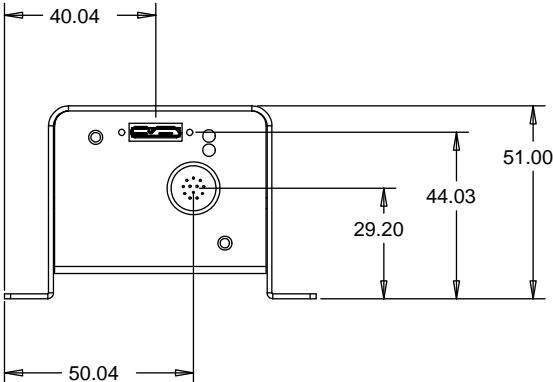

Figure 8: Enclosed Model – USB Side View



## CL-U3B-IND OEM Board Set

Figure 9: iPORT CL-U3B-IND OEM Board Set

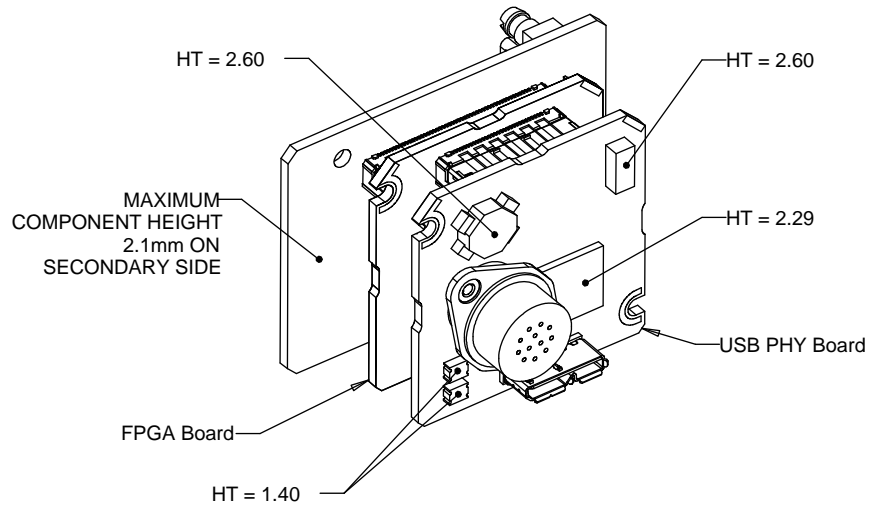

Figure 10: iPORT CL-U3B-IND OEM Board Set

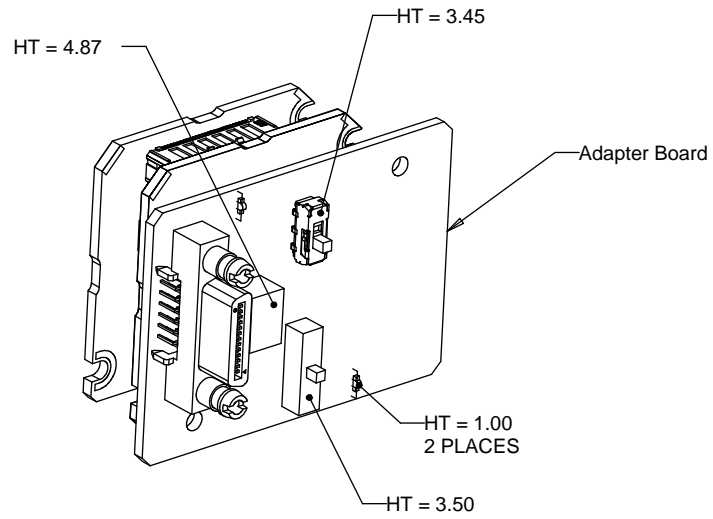

Figure 11: iPORT CL-U3B-IND OEM Board Set

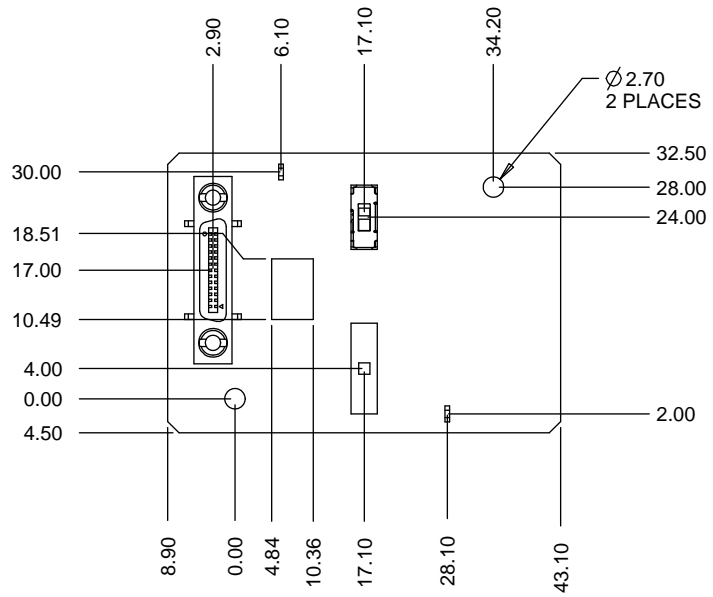
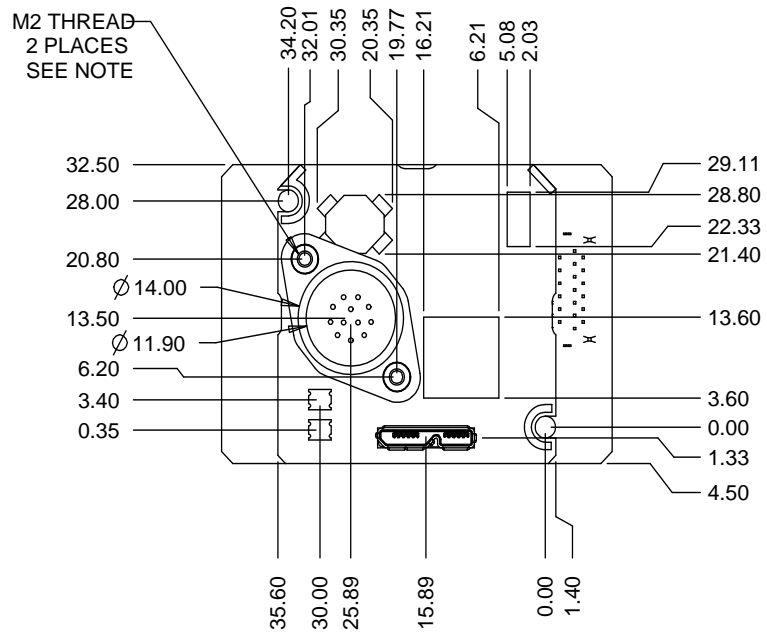
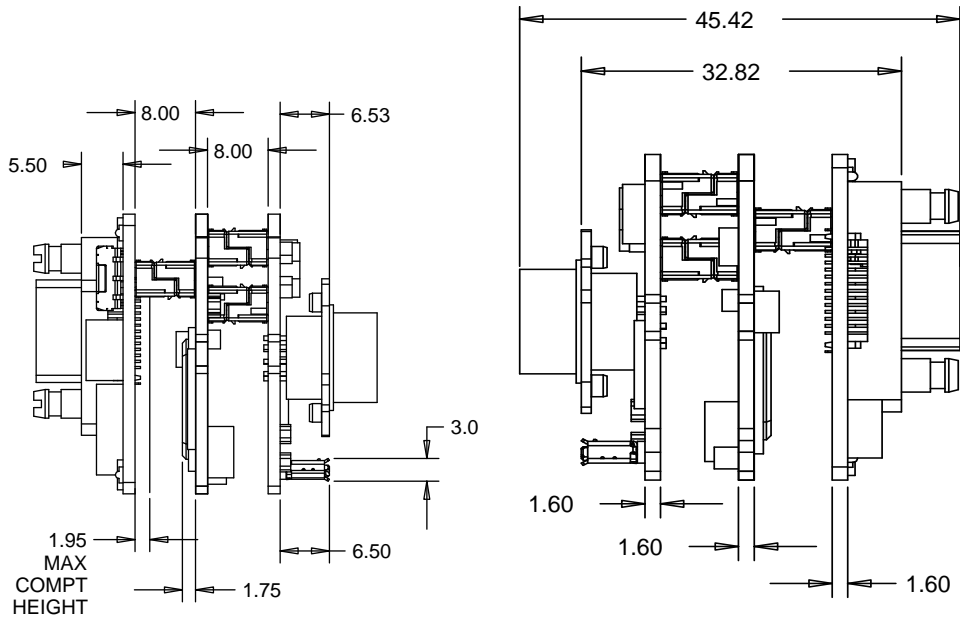

Figure 12: iPORT CL-U3B-IND OEM Board Set



NOTE: CONNECTOR DIMENSIONED TO CENTER.

Figure 13: iPORT CL-U3B-IND OEM Board Set



NOTE: JACK SOCKETS WILL BE FASTENED TO CUSTOMER PANEL.  
PANEL THICKNESS WILL ADD TO THIS DIMENSION.

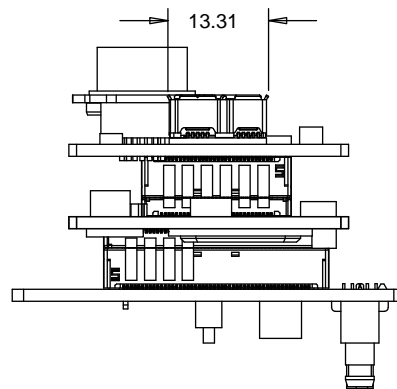

## CL-U3M-IND OEM Board Set

Figure 14: iPORT CL-U3M-IND OEM Board Set

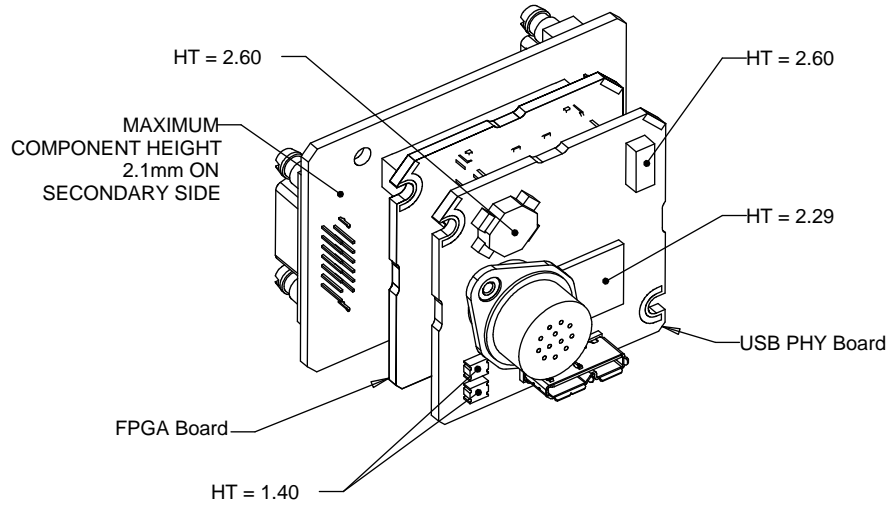

Figure 15: iPORT CL-U3M-IND OEM Board Set

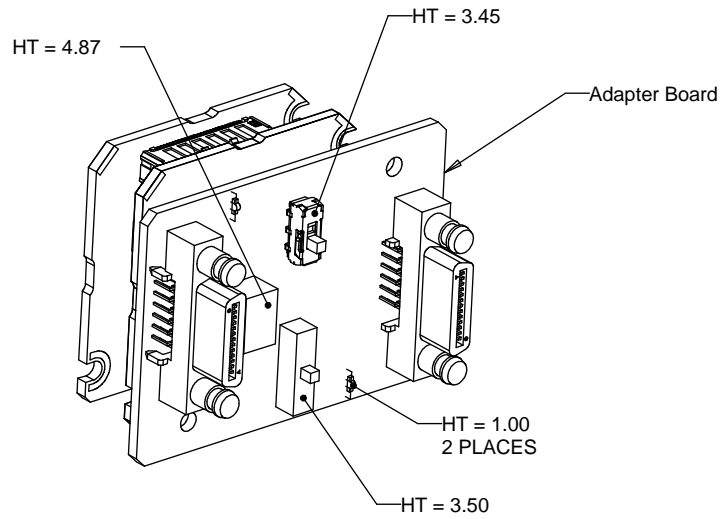

Figure 16: iPORT CL-U3M-IND OEM Board Set

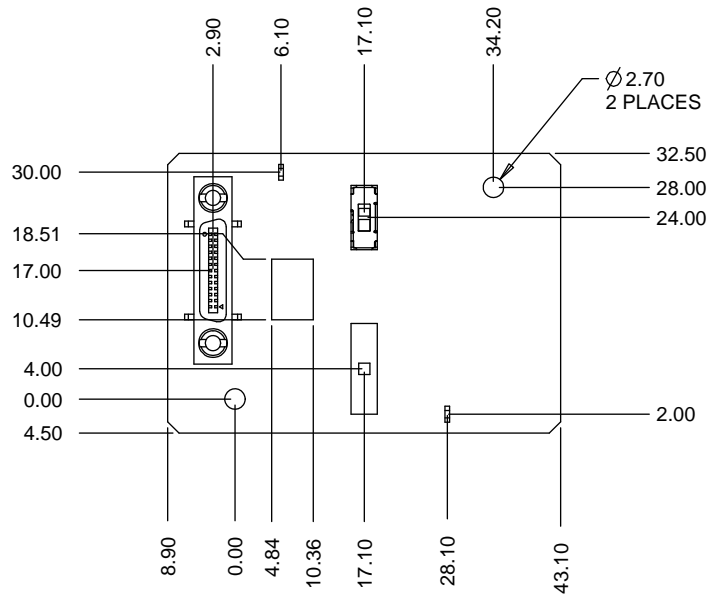
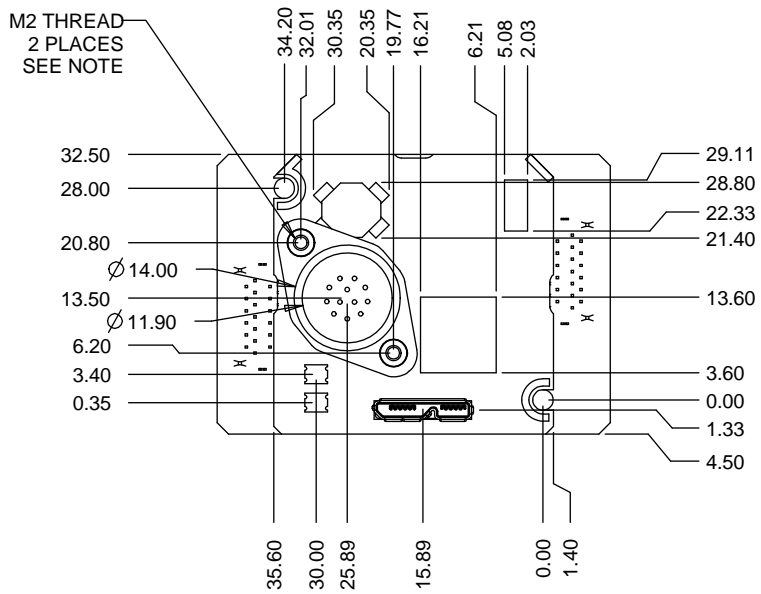

Figure 17: iPORT CL-U3M-IND OEM Board Set



NOTE: FASTENERS USED IN BRACKET ARE M2 X 0.4.  
 MAXIMUM THREAD DEPTH IS 4MM BEYOND  
 BRACKET FACE.



Figure 18: iPORT CL-U3M-IND OEM Board Set

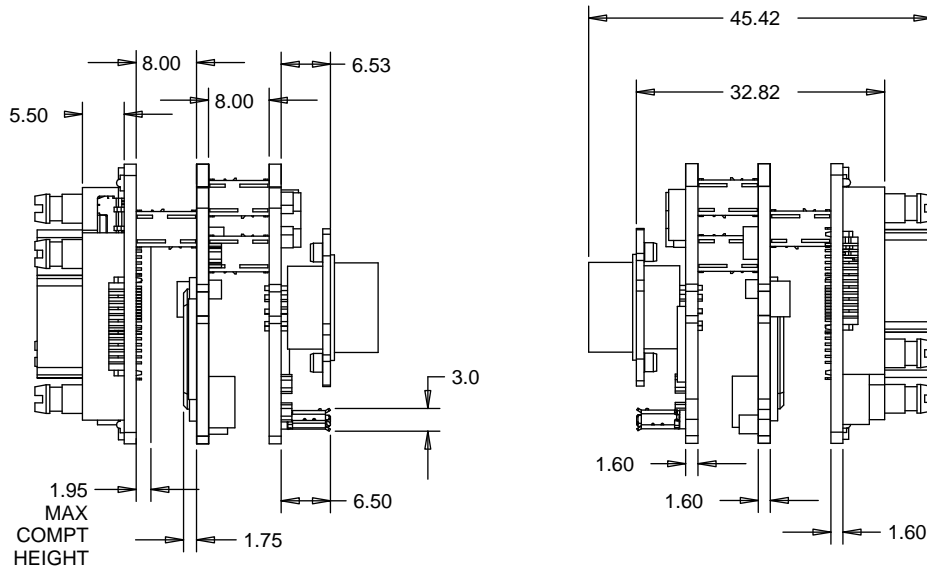

NOTE: JACK SOCKETS WILL BE FASTENED TO CUSTOMER PANEL  
PANEL THICKNESS WILL ADD TO THIS DIMENSION.

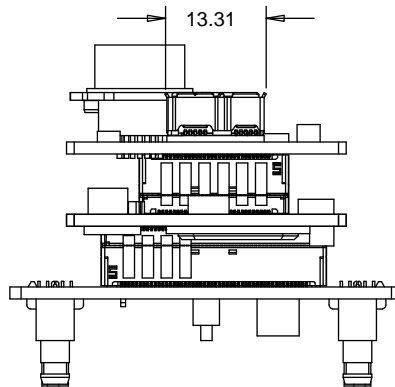

## GPIO Board Assembly

Figure 19: GPIO Board – Front and Back Views

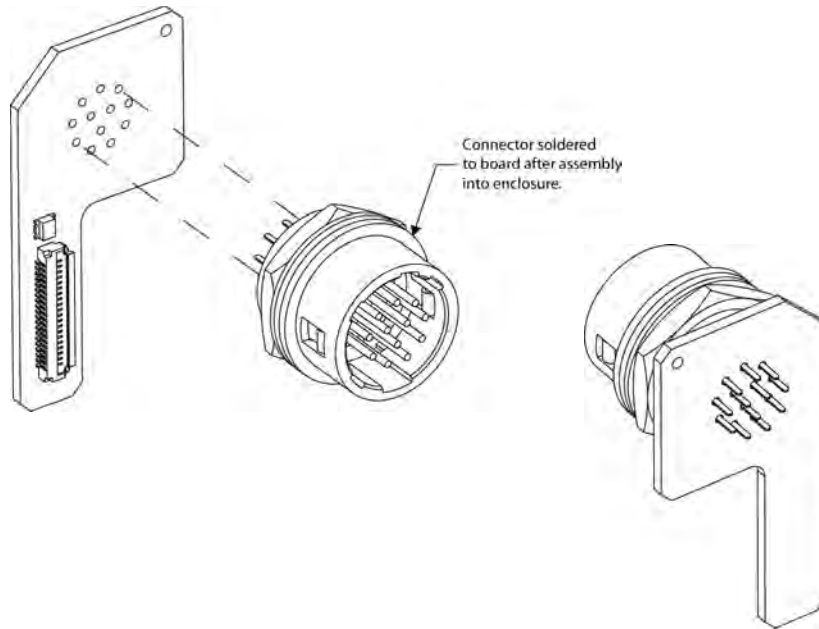

Figure 20: GPIO Board – Dimensions

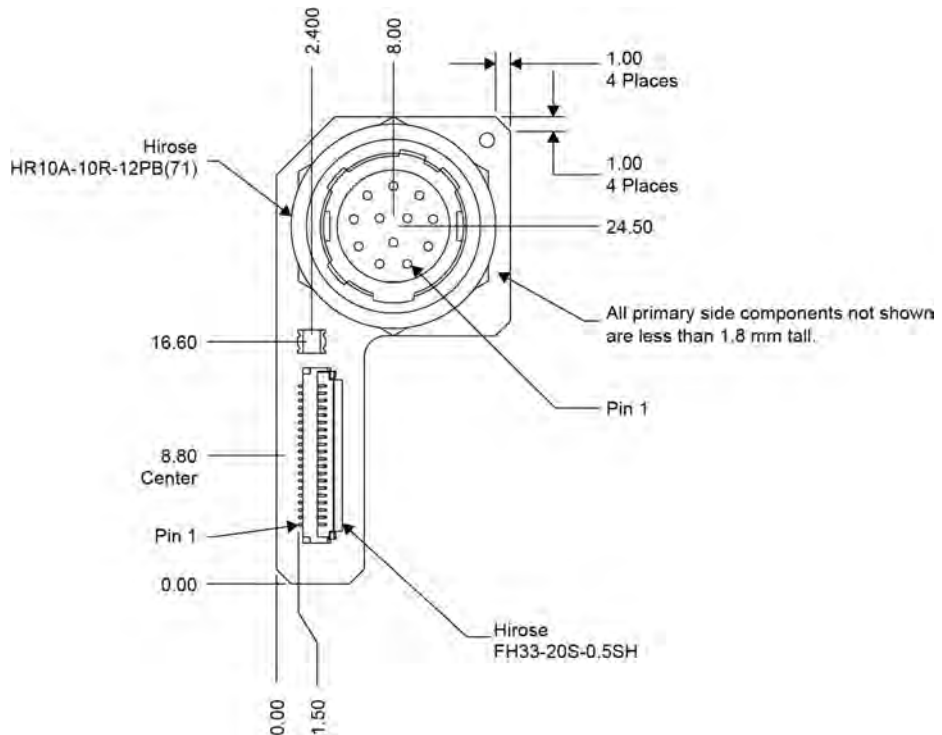

Figure 21: GPIO Board – Dimensions (Continued)

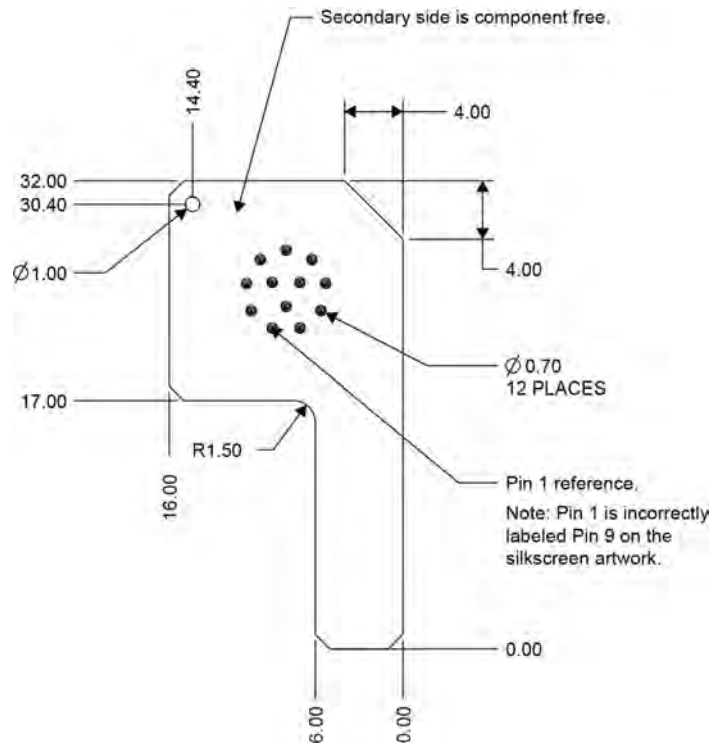
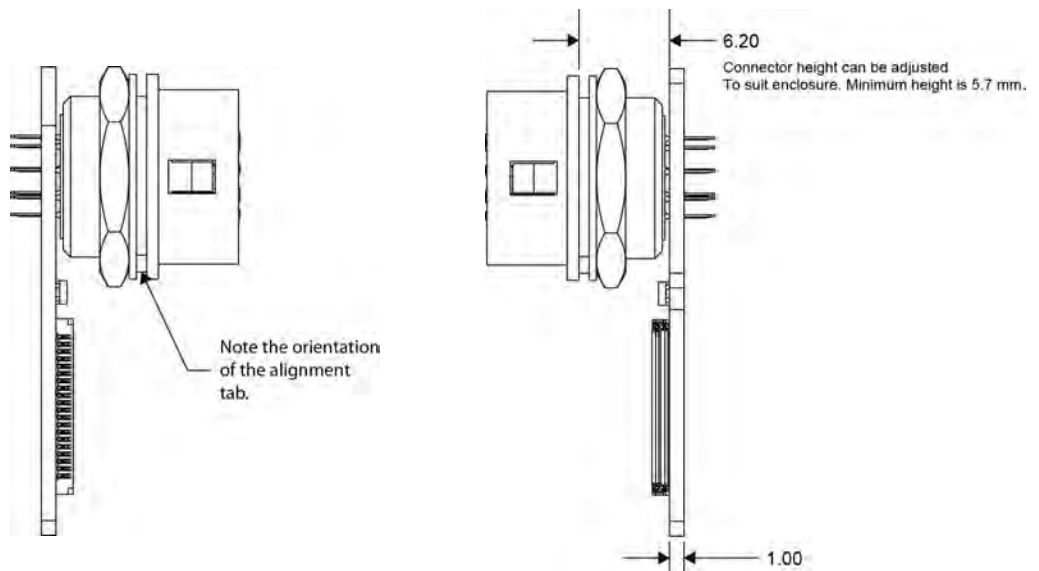

Figure 22: GPIO Board – Side Views



## Material List

The connector summaries for the CL-U3 are listed in the following table.

Table 34: Connector Summary

Description	Manufacturer part number	Manufacturer
Micro-B USB 3.0 connector	897-10-010-00-300002	Mill-Max Mfg. Corp.
12-pin circular connector	HR10A-10R-12PB(71)	Hirose Electric Co. Ltd.
Miniature Camera Link	12226-1100-00FR	3M



Source manufacturer, description, and identification may vary for each connector.

## Using USB3 Vision Locking Cables with the Inverted Micro-B USB 3.0 Connector

The CL-U3 uses a USB 3.0 Micro-B connector in an inverted configuration, which affects use with cables that right-angled USB 3.0 Micro-B connectors. The following table provides guidance for selecting the appropriate cable.



Table 35: USB3 Vision Locking Cables Orientation on CL-U3

Desired cable exit angle	Cable type to use
Up	Right-Angle Down
Down	Right-Angle Up
Right	Right-Angle Left
Left	Right-Angle Right
Straight	Straight

# Chapter 12



## Appendix: Timing for Camera Link Base/Medium Signals

The output of the camera must match the format of the CL-U3. You should select a case for your application and then refer to “[Timing Values for All Cases](#)” on page 95. The stated timing restrictions are minimum values.

# Camera Link Signals

## Case 1: FVAL and LVAL are Level-Sensitive

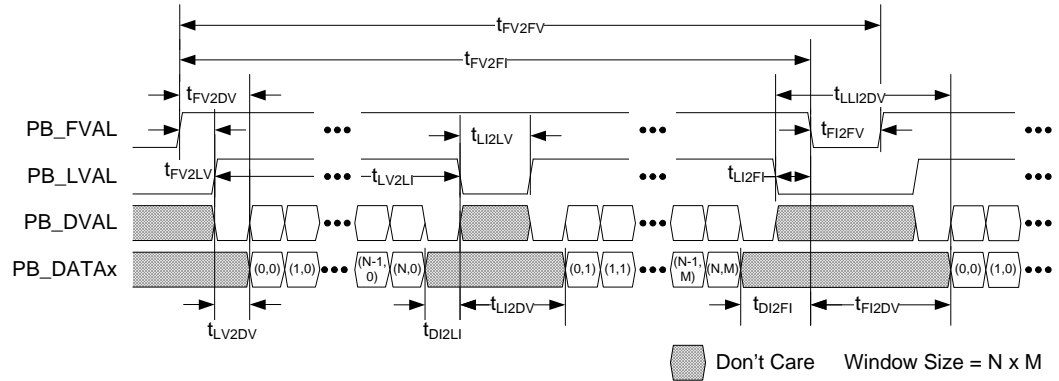

## Case 2: FVAL and LVAL are Edge-Sensitive

In this case, FVAL and LVAL are edge-sensitive.

- **Start of frame/line is signaled by:** A rising (or falling) edge on FVAL, which signals the start of a *frame*. A rising (or falling) edge on LVAL, which signals the start of a *line*.
- **End of frame is signaled by:**
  - The next FVAL valid edge (rising edge when rising-edge sensitive or falling edge when falling-edge sensitive) occurs.
  - Or, when all of the pixels have been acquired (as set in the image height and width settings) **AND** an end-of-frame (EOF) occurs.  
Note: EOF occurs at LVAL rising edge (when rising-edge sensitive) or LVAL falling edge (when falling-edge sensitive). This is an additional LVAL edge, in addition to the configured/expected number of lines. See the EOF indicator in the illustration below.
- **Line Missing status and Partial Line Missing errors:** Partial Line Missing indicates lines are ending early (the next LVAL valid edge occurs before all of the pixels have been acquired). Full Line Missing indicates that the frame is ending early (the next FVAL edge occurs before all of the lines have been acquired).

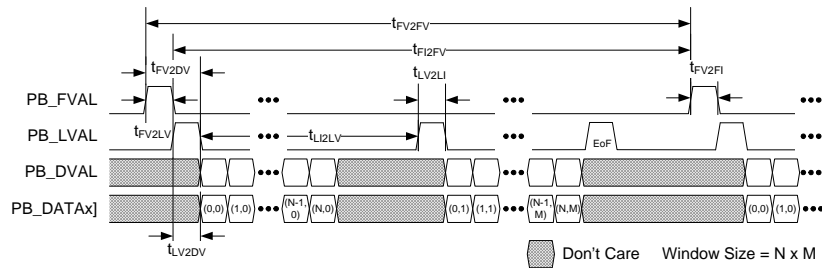

### Case 3: FVAL is Edge-Sensitive and LVAL is Level-Sensitive

In this case, FVAL is edge-sensitive and LVAL is level-sensitive.

- **Start of frame/line is signaled by:** A rising (or falling) edge on FVAL, which signals start of *frame*. The line is valid when LVAL is active (high or low depending on settings).
- **End of frame is signaled by:**
  - The next FVAL valid edge (rising edge when rising-edge sensitive or falling edge when falling-edge sensitive) occurs.
  - Or when all of the lines have been acquired (as set in the image height settings) **AND** the last LVAL with valid data is de-asserted (low when high level sensitive or high when low level sensitive).
- **Line Missing status or a Partial Line Missing error generated:**
  - Full Line Missing indicates that the frame is ending early (the next FVAL edge occurs before all of the lines have been acquired). Partial Line Missing indicates that lines are ending early (in this case, LVAL is de-asserted before all pixels in a line are captured).

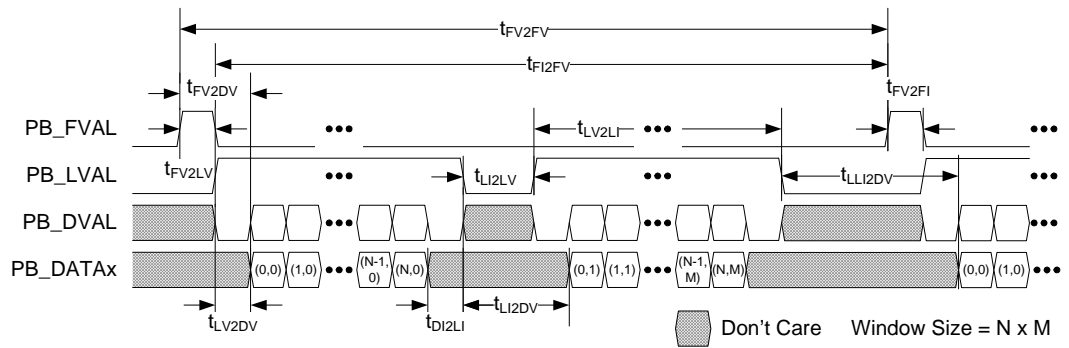

## Timing Values for All Cases

The timing values stated in the following table are minimum values only.

Table 36: Timing Values for All Cases

From	To	Symbol	Case 1 (level) ( $t_{cp}$ )	Case 2 (edge) ( $t_{cp}$ )	Case 3 (both) ( $t_{cp}$ )
FVAL valid	LVAL valid <sup>a</sup>	$t_{FV2LV}$	0 <sup>b</sup>	0	1
FVAL valid	Data valid <sup>a, c, d</sup>	$t_{FV2DV}$	0 <sup>b</sup>	16	1
LVAL valid	Data valid <sup>a, c, d</sup>	$t_{LV2DV}$	0	1	0
LVAL valid	LVAL invalid <sup>a</sup>	$t_{LV2LI}$	1	1	1
LVAL invalid	LVAL valid <sup>a</sup>	$t_{LI2LV}$	1	1	1
LVAL invalid (Automatic Internal Retrigger disabled)	Data valid <sup>a, c, d</sup>	$t_{LI2DV}$	1	N/A	1
LVAL invalid (Automatic Internal Re-trigger enabled)	Data valid	$t_{LI2DV}$	16	N/A	16
Data invalid	LVAL invalid <sup>a, c, d</sup>	$t_{DI2LI}$	0	N/A	0
LVAL invalid	FVAL invalid <sup>a</sup>	$t_{LI2FI}$	0 <sup>e</sup>	N/A	N/A
Data invalid	FVAL invalid <sup>a, c, d</sup>	$t_{DI2FI}$	0 <sup>e</sup>	N/A	N/A
FVAL invalid	FVAL valid <sup>a</sup>	$t_{FI2FV}$	1	1	1
FVAL invalid	Data valid <sup>a, c, d</sup>	$t_{FI2DV}$	1	N/A	N/A
Last LVAL invalid	Data valid	$t_{LLI2DV}$	16	N/A	16
FVAL valid	FVAL invalid	$t_{FV2FI}$	16	1	1
FVAL valid	FVAL valid	$t_{2FV2FV}$	17	17	17

- a.** The valid state of FVAL and LVAL is high when they are set as level-high sensitive or rising-edge sensitive. Their valid state is low when they are set as level-low sensitive or falling-edge sensitive.
- b.** If LVAL is valid before FVAL becomes valid, the grabber drops the full line.
- c.** Data valid is defined by FVAL valid (note a), LVAL valid (note a), and DVAL valid (note d).
- d.** The valid state of DVAL is high when it is set as level-high sensitive, and low when set as level-low sensitive. DVAL is always valid in the grabber when the parameter **PixelBusDataValidEnabled** is off.
- e.** If FVAL becomes invalid and LVAL is still valid, the line is truncated.







# Chapter 13



## Reference: Mean Time Between Failures (MTBF) Data

The following table provides MTBF data.

Table 37: MTBF Data

Model	MTBF @ 40 °C
CL-U3B External Frame Grabber	1,135,333 hours
CL-U3M External Frame Grabber	
CL-U3B-IND External Frame Grabber	958,332 hours
CL-U3M-IND External Frame Grabber	

### Assumptions:

1. The calculation is performed using the *RelCalc for Windows V5.1-TELC3* software, which implements Telcordia SR-332 (Issue 3) failure rate models.
2. The operating internal chassis temperature is 40°C. The calculation assumes the temperature across the boards is relatively constant.
3. The Telcordia environment is GB.
4. Each part's operating current/voltage/power stress is 50%.
5. The typical operating power value (as specified in the component's datasheet) is used for each IC and semiconductor.
6. The calculation uses the 90% UCL (Upper Confidence Level) Telcordia Issue 3 model.
7. Each part's Telcordia Quality Level is I.



# Chapter 14



## Reference: Regulatory Statements

This chapter provides regulatory statements for the CL-U3, and pertain specifically to the following products.

Table 38: CL-U3 Regulatory Statements

Order code	Model
903-0007	iPORT CL-U3B External Frame Grabber
903-0008	iPORT CL-U3M External Frame Grabber
903-0009	iPORT CL-U3B-IND External Frame Grabber
903-0010	iPORT CL-U3M-IND External Frame Grabber

## United States & Canada

These devices comply with FCC Part 15 standard(s). Operation is subject to the following two conditions:

1. This device may not cause interference.
2. This device must accept any interference, including interference that may cause undesired operation of the device.

This equipment has been tested and found to comply with the limits for a Class B digital device, pursuant to part 15 of the FCC Rules. These limits are designed to provide reasonable protection against harmful interference in a residential installation. This equipment generates, uses, and can radiate radio frequency energy and, if not installed and used in accordance with the instructions, may cause harmful interference to radio communications. However, there is no guarantee that interference will not occur in a particular installation. If this equipment does cause harmful interference to radio or television reception, which can be determined by turning the equipment off and on, the user is encouraged to try to correct the interference by one or more of the following measures:

- Reorient or relocate the receiving antenna.
- Increase the separation between the equipment and receiver.
- Connect the equipment into an outlet on a circuit different from that to which the receiver is connected.
- Consult the dealer or an experienced radio/TV technician for help.

Changes or modifications not expressly approved by the party responsible for compliance could void the user's authority to operate the equipment.

CAN ICES-3 (B)/NMB-3(B) - This Class B Digital Apparatus Complies with Canadian ICES-003.

Cet Appareil numerique de la classe (B) est conforme a la norme NMB-003 du Canada.

## European Union

These devices comply to the EC directive 2014/30/EC - Electromagnetic Compatibility Directive under Class B ITE equipment. They have been tested and found to comply with EN 55024:2010, EN 55032:2012/AC 2013 and EU Directive 2011/65/EU.



These are Class B products. In a domestic environment, these products may cause radio interference; in this case, the user may be required to take adequate measures.

# Chapter 15



## Technical Support

On the Pleora Support Center, you can:

- Download the latest software and firmware.
- Log a support issue.
- View documentation for current and past releases.
- Browse for solutions to problems other customers have encountered.
- Read knowledge base articles for information about common tasks.

### To visit the Pleora Support Center

- Go to [supportcenter.pleora.com](http://supportcenter.pleora.com).

Most material is available without logging in to a Support Center account. To access software and firmware downloads, in addition to other content, log in to the Support Center. If you do not have an account, click **Request Account**.

Accounts are usually validated within one business day.

